



ZARGES



ZARGES

» Medical

www.zarges-medical.com



“For me, nursing is about taking care of my patients!”

ZARGES Medical: People are our priority.

Uncompromising quality combined with continuous innovation – for more than 85 years this is what ZARGES has stood for. The decades of brand and innovation leadership also stands behind our products and solutions for the medical sector.

Our goal is to give nursing staff the best possible support in their daily work and to do it as efficiently and economically as possible.

Our products and services provide integrated logistics solutions for expendable and durable goods in the healthcare sector. with professional advice, organisation, equipment and service from a single source.

Whether the requirement is for storage and transport systems, mobile organisation systems or solutions for supply and disposal, **it is always people that take centre stage at ZARGES.**

Our promise: ZARGES Medical, storage and transport processes in nursing and operational areas dovetail seamlessly. This means lower costs, greater efficiency and motivated personnel.

Innovations for people

We are continuously optimising our products and services and extending our service provision with one major aim: to have a professional and customised logistic solution ready for you for any task and any situation in the care sector.

If you have any queries, require specific solutions or further information, our service team will be happy to help you:

Tel: +49 (0)881 687-132
E-Mail: medical@zarges.de
www.zarges-medical.com

ZARGES Medical

Brand promise	2
Products & solutions	4-5
Innovations	6-7
Service	8-9

Storage systems

Product overview	12-13
Supply chain	14-15
Modules and modular baskets	16-21
Labelling	22-23
Cabinet systems	24-27
Support systems	28-31
Cupboard accessories	32-35
Planning cabinet systems	36
Height units	37
Cupboard units	38-41
Fittings and locking systems	42
Colour range	43
Planning aids for cabinet systems	44-49
Shelving system	50-65
Storage and retrieval trolley	66-69
MPO storage trolleys	70-79
Mobile cases	80-81

Mobile organisation systems

Product overview	84-85
MPO transportation trolley	86-91
MPO nursing trolleys	92-93
MPO medication trolleys	94-95
MPO anaesthesia trolleys	96-97
MPO emergency trolleys	98-99
MPO dressing trolleys	100-101
MPO IT trolleys	102-103
Accessories for MPO transportation trolleys	104-108
MPO configurator	109
Locking systems	110-111
Multi-function trolley	112-113
Medication distribution systems	114-119

Transport systems

Product overview	122-123
W 105 N cupboard trolley	124-131
W 170/W 171/W 172 box trolleys	132-137
Spring-loaded trolley	138-139
Driverless transport systems	140-141
Electric drive assist	142-143
Cage trolleys	144

Supply and disposal

Product overview	148-149
CIC trolley systems for sterile areas	150-153
Hazardous goods packaging	154-155
Waste collection systems	156-157
Accessories for laundry collection system	158-159

Packaging

Product overview	162-163
K 424 XC	164-165
K 470 universal container	166-167
Interior fittings	168-170
Accessories	171

Access

Product overview	174-175
Shelf ladders	176-177
Stepladders, single-sided access	178
Stepladders, double-sided access	179
Step stools	180-181
Pax Tower 1T folding scaffold unit	182-183

Information and service

Alphabetical index	190
Numerical search index	191-193
General Terms and Conditions	194

Efficient, cost-effective, from a single source: Our system solutions.

When it comes to people's health, everything has to run smoothly and quickly. We support hospitals and other health facilities in ensuring the highest quality and complete security of supply.

Our products and solutions help to efficiently and logistically coordinate the many complex processes and structures in the areas of personnel, care and material flows. This achieves medical services of the highest quality and optimum cost-effectiveness.



Packaging // page 160-171

Optimum packaging solutions with ZARGES cases and accessories.



Access // page 172-183

Safe working at heights with ZARGES ladders, steps and scaffold units.



Storage systems // page 10–81

Integrated modular storage systems to ISO standard, with modules, modular furnishings, shelving and corresponding accessories.



Mobile organisation systems // page 82–119

Products to support ward-internal processes and mobile storage in nursing, medication distribution, during ward rounds and in services.



Transport systems // page 120–145

Universal products for the protected transport of medical goods.



Supply and disposal // page 146–159

Products for the safe and hygienic supply and disposal of recyclables, laundry and sterile goods.





ZARGES shelving system: A solution with endless possibilities. This flexible system can be adapted to suit the specific requirements. The modular design means that all components can be combined with the other ZARGES modular systems.

INNOVATIONS

ZARGES shelving system – innovative in serving people.

Our mission is clear: to support nursing staff in their daily work in the best possible way with innovative products and solutions. To this end, we are consistently working on new, sophisticated and optimised logistics solutions for expendable and durable goods in the healthcare sector.

One example of our innovative solutions is the new ZARGES shelving system – a system with endless possibilities. It can be flexibly adapted to requirements, individually assembled and configured using various modules and modular

baskets, and can be combined with other ZARGES systems. For more efficient work and maximum cost-effectiveness for the long term.

Whether the requirement is for storage and transport systems, mobile organisation systems or solutions for supply and disposal, Discover in this catalogue our innovations for any care task and situation.



The ZARGES digital locking system:
Simply more secure.

Open to all, accessible only to authorised persons.



MPO storage trolley with glass door.

Keeps items in sight and readily accessible.



MPO product configurator

The online configurator enables customers to easily customise their MPO trolleys and to visualise the configured trolley as well as receiving a quotation.



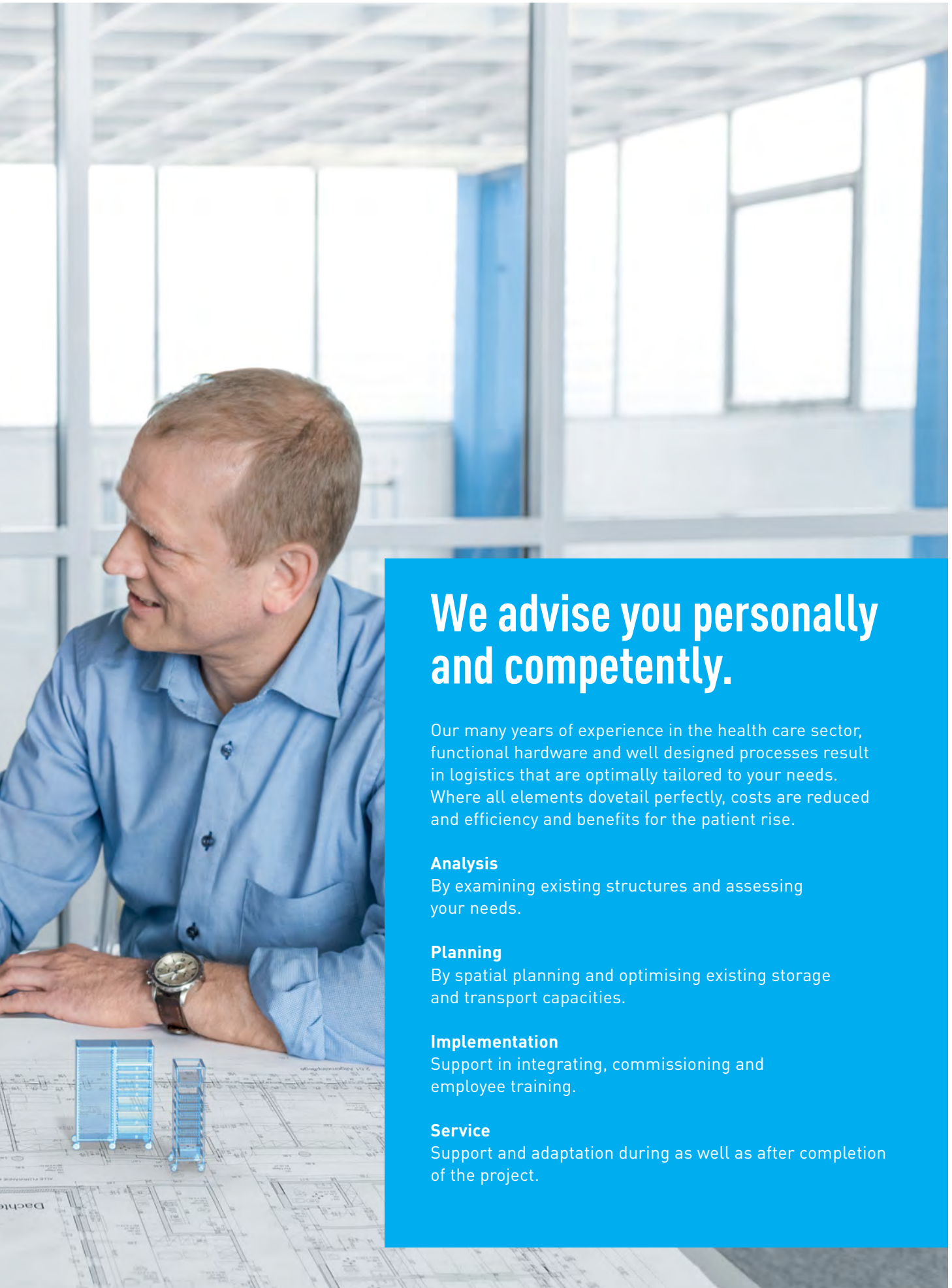

We advise you personally and competently.

Our many years of experience in the health care sector, functional hardware and well designed processes result in logistics that are optimally tailored to your needs. Where all elements dovetail perfectly, costs are reduced and efficiency and benefits for the patient rise.

Analysis

By examining existing structures and assessing your needs.

Planning

By spatial planning and optimising existing storage and transport capacities.

Implementation

Support in integrating, commissioning and employee training.

Service

Support and adaptation during as well as after completion of the project.



Medical

Storage systems

Integrated modular storage systems to ISO standard, with modules, modular furnishings, shelving and corresponding accessories.

Product overview	12–13
Supply chain	14–15
Modules and modular baskets	16–21
Labelling	22–23
Cabinet systems	24–27
Support systems	28–31
Cupboard accessories	32–35
Planning cabinet systems	36
Height units	37
Cupboard units	38–41
Fittings and locking systems	42
Colour range	43
Planning aids for cabinet systems	44–49
Shelving system	50–65
Storage and retrieval trolley	66–69
MPO storage trolleys	70–79
Mobile cases	80–81



Equipment for central storage facilities and storage and retrieval trolleys



Modular storage variants



Storage of medications



Storage systems for sterile goods



Modular cabinet system



"Traffic light" labelling system

The optimised supply chain.

An efficient supply chain is the basis for productive and transparent logistics. ZARGES products support an integrated flow of materials from requisition through to the point of consumption.

Material use



Nursing trolleys, dressing trolleys etc.

Departmental storage



Storage in nursing and operational areas

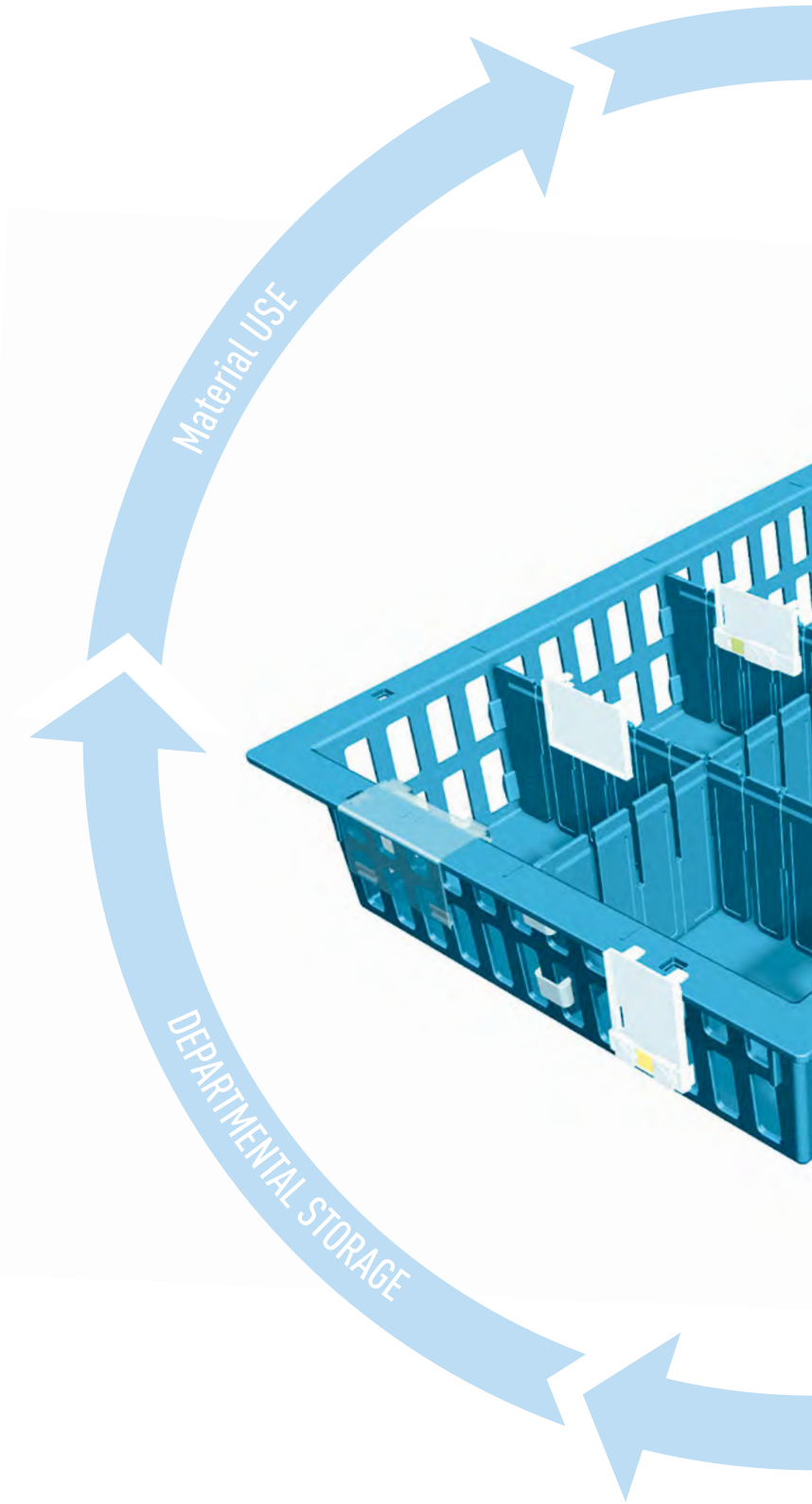

Central storage facility



Modular goods storage system

Storage and retrieval



Mobile modular stock picking

Transport



Protected transport of goods

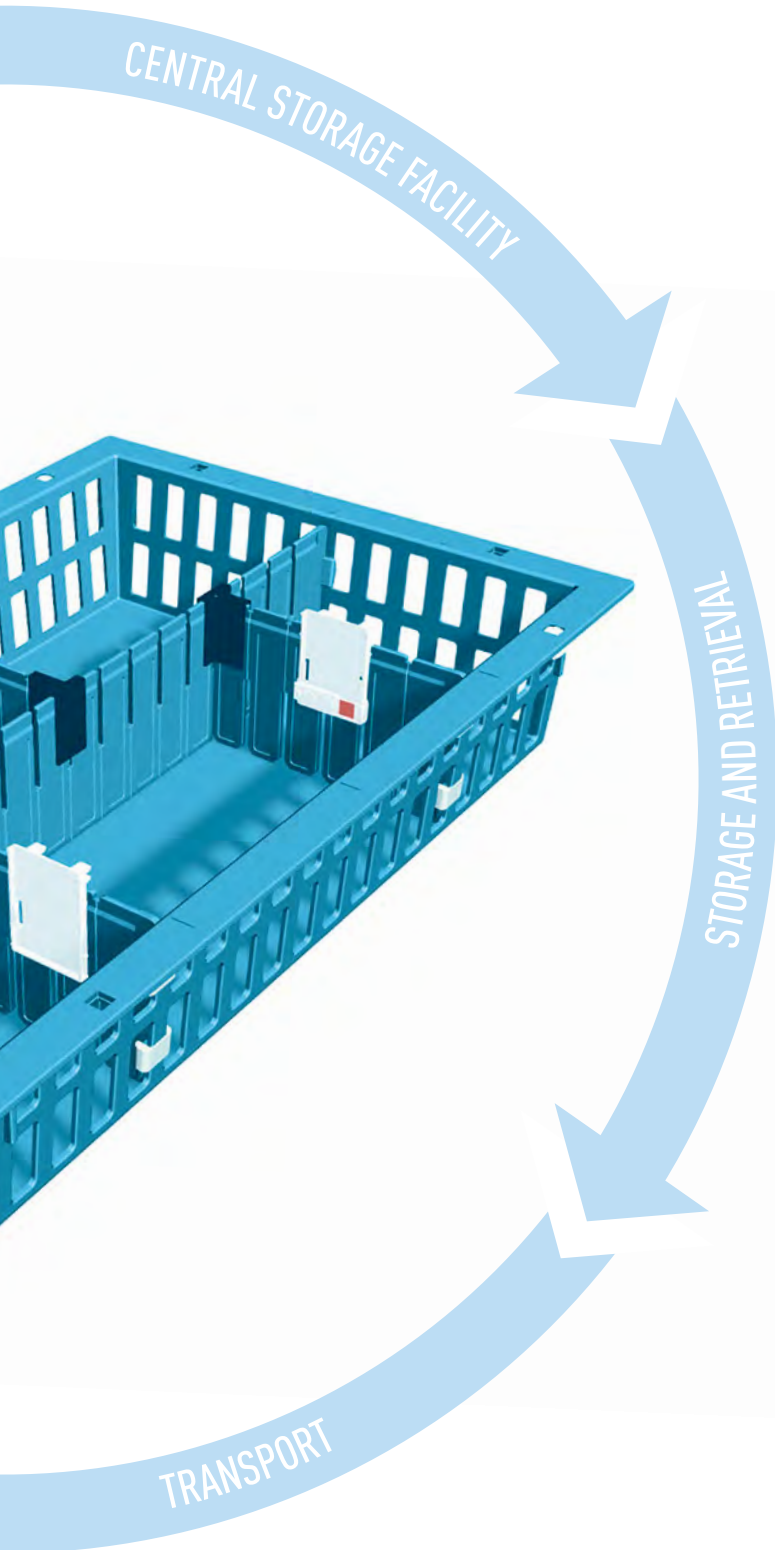

Practical whatever the task in hand: Modules and modular baskets.

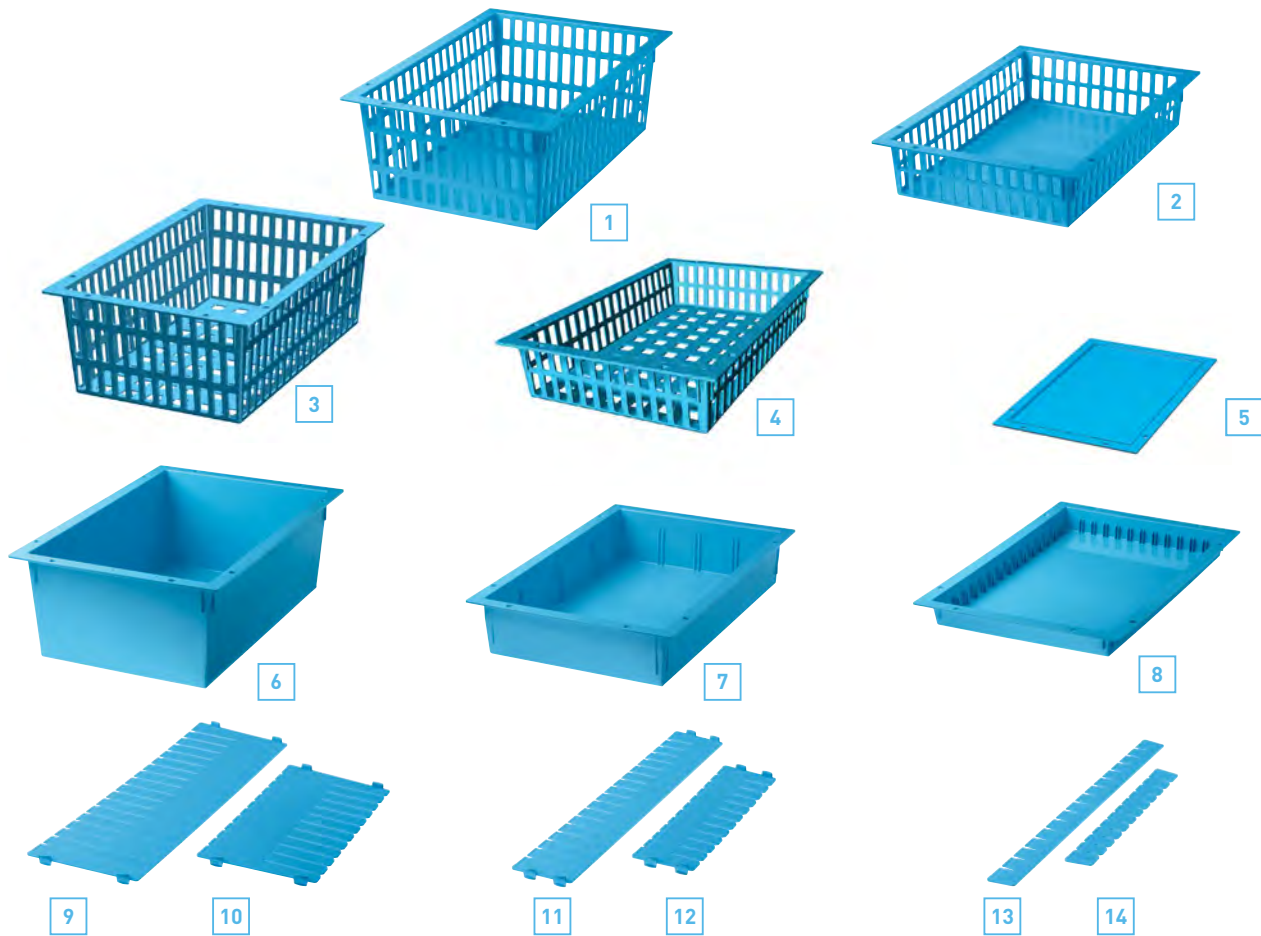

ABS modules and ABS modular baskets, 600 × 400 mm

- ▶ Made from acrylonitrile butadiene styrene (ABS), light blue.
- ▶ Modules and modular baskets are stackable and nestable.
- ▶ Heat-resistant to 85 °C.
- ▶ Sealed floor provides reliable protection against spilled liquids, dust and dirt particles. Optionally with perforated floor.
- ▶ Simple mounting of label holders regardless of the position of the lengthwise and crosswise dividers.
- ▶ Can be subdivided as required, visual aids for positioning of dividers.
- ▶ Designed for fitting in a support wall and on telescopic rails and includes safety stop system.
- ▶ Fits in accordance with ISO standard 3394.

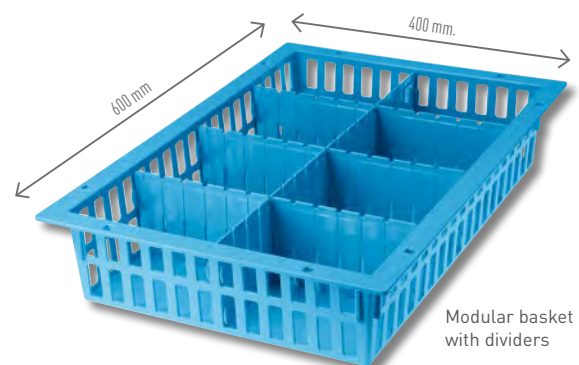

No.	Order no.	Designation	Dimensions, L × W × H, approx. mm
1	46000	ABS modular basket	600 × 400 × 200
2	46005	ABS modular basket	600 × 400 × 100
3	46529	ABS modular basket with perforated floor	600 × 400 × 200
4	46528	ABS modular basket with perforated floor	600 × 400 × 100
5	46201	ABS module lid	600 × 400 × 15
6	46200	ABS module (not sub-dividable)	600 × 400 × 200
7	46202	ABS module	600 × 400 × 100
8	46011	ABS medication module	600 × 400 × 50

Matching dividers

No.	Order no.	Designation	Dimensions, L × H, approx. mm
9	46027	Lengthwise divider for 46000/46209	600 × 200
10	46028	Crosswise divider for 46000/46209	400 × 200
11	46029	Lengthwise divider for 46005/46202/46208	600 × 100
12	46030	Crosswise divider for 46005/46202/46208	400 × 100
13	46034	Lengthwise divider for 46011	600 × 50
14	46035	Crosswise divider for 46011	400 × 50

Reliable even at high temperatures: Modules and modular baskets in PC.



PC modules, PC modular baskets and PC dividers, 600 × 400 mm

- ▶ Made from polycarbonate (PC), transparent.
- ▶ Modules and modular baskets are stackable and nestable.
- ▶ Heat-resistant to 125 °C.
- ▶ Sealed floor provides reliable protection against spilled liquids and dust.
- ▶ Simple mounting of label holders regardless of the position of the lengthwise and crosswise dividers.
- ▶ Can be subdivided as required, visual aids for positioning of dividers.
- ▶ Slots for lengthwise and crosswise dividers.
- ▶ Designed for fitting in a support wall and on telescopic rails and includes safety stop system.
- ▶ Fits in accordance with ISO standard 3394.

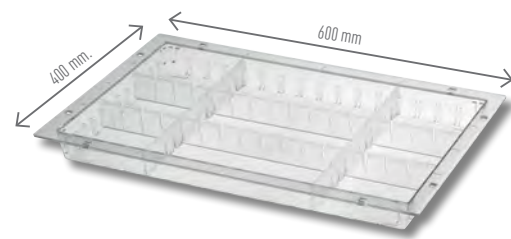

PC medication module with dividers

No.	Order no.	Designation	Dimensions, L × W × H, approx. mm
1	46001	PC modular basket	600 × 400 × 200
2	46004	PC modular basket	600 × 400 × 100
3	46203	PC module	600 × 400 × 100
4	46010	PC medication module	600 × 400 × 50

Matching dividers

No.	Order no.	Designation	Dimensions, L × H, approx. mm
5	46040	Lengthwise divider for 46001	600 × 200
6	46041	Crosswise divider for 46001	400 × 200
7	46042	Lengthwise divider for 46004/46203/46205	600 × 100
8	46043	Crosswise divider for 46004/46203/46205	400 × 100
9	46031	Lengthwise divider for 46010/46204	600 × 50
10	46032	Crosswise divider for 46010/46204	400 × 50

Organisation aids in every size: PC half-modules and PC dividers.



PC half-modules and PC dividers, 300 × 400 mm

- ▶ Made from polycarbonate (PC), transparent.
- ▶ Stackable and nestable.
- ▶ Heat-resistant to 125 °C.
- ▶ Sealed floor provides reliable protection against spilled liquids and dust.
- ▶ Easy attachment of the label holders.
- ▶ Slots for lengthwise and crosswise dividers.
- ▶ Designed for fitting in a support wall and on telescopic rails and includes safety stop system.

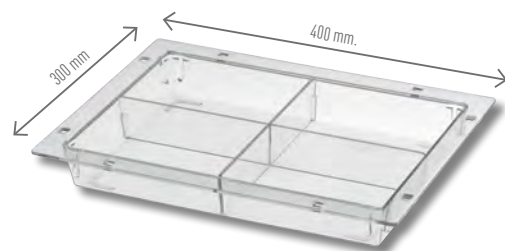

PC half-module with dividers

No.	Order no.	Designation	Dimensions, L × W × H, approx. mm
1	46003	PC half-module	300 × 400 × 100
2	46002	PC half-module	300 × 400 × 50
3	46006	PC half-module, can be subdivided	300 × 400 × 100
4	46007	PC half-module, can be subdivided	300 × 400 × 50

Dividers to fit PC modules, 300 × 400 mm

No.	Order no.	Designation	Dimensions, L × H, approx. mm
5	46036	Lengthwise divider for 46006	400 × 100
6	46037	Crosswise divider for 46006	300 × 100
7	46038	Lengthwise divider for 46007	400 × 50
8	46039	Crosswise divider for 46007	300 × 50

PC submodule and dividers

No.	Order no.	Designation	Dimensions, L × W × H, approx. mm
9	46021	Submodule can be used as insert for modules/modular baskets	240 × 110 × 75
10	46033	Crossways divider for submodule	103 × 73 (L × H)

Easily variable: Modular drawers in ABS.



Modular drawers in ABS

- ▶ Made from acrylonitrile butadiene styrene (ABS), light grey.
- ▶ Heat-resistant to 85 °C.
- ▶ Sealed floor provides reliable protection against spilled liquids and dust.
- ▶ Can be subdivided as required using lengthwise and crosswise dividers.
- ▶ Designed for fitting in a support wall and on telescopic rails and includes safety stop system.
- ▶ Designed for attachment of label holders.



No.	Order no.	Designation	Dimensions, L × W × H, approx. mm
1	46206	ABS modular drawer	600 × 400 × 225/245
2	46205	ABS modular drawer	600 × 400 × 125/145
3	46209	ABS modular drawer	400 × 600 × 225/245
4	46208	ABS modular drawer	400 × 600 × 125/145
5	46204	ABS modular drawer	600 × 400 × 75/95
12	46466	ABS modular drawer, lockable	600 × 400 × 150
13	46468	ABS modular drawer, lockable	400 × 600 × 150

Matching dividers

No.	Order no.	Designation	Dimensions, L × H, approx. mm
6	46040	Lengthwise divider for 46206	600 × 200
7	46041	Crosswise divider for 46206	400 × 200
8	46042	Lengthwise divider for 46203/46205	600 × 100
9	46043	Crosswise divider for 46203/46205	400 × 100
10	46031	Lengthwise divider for 46204	600 × 50
11	46032	Crosswise divider for 46204	400 × 50

Accessories for modules and modular baskets.

Efficient supply, seamless ordering process, flexible and hygienic storage: The requirements placed on logistics in the medical sector are usually high. Practical and well thought-out ZARGES accessories for modules and module baskets support efficient working for continuous materials flow and thus optimum care.

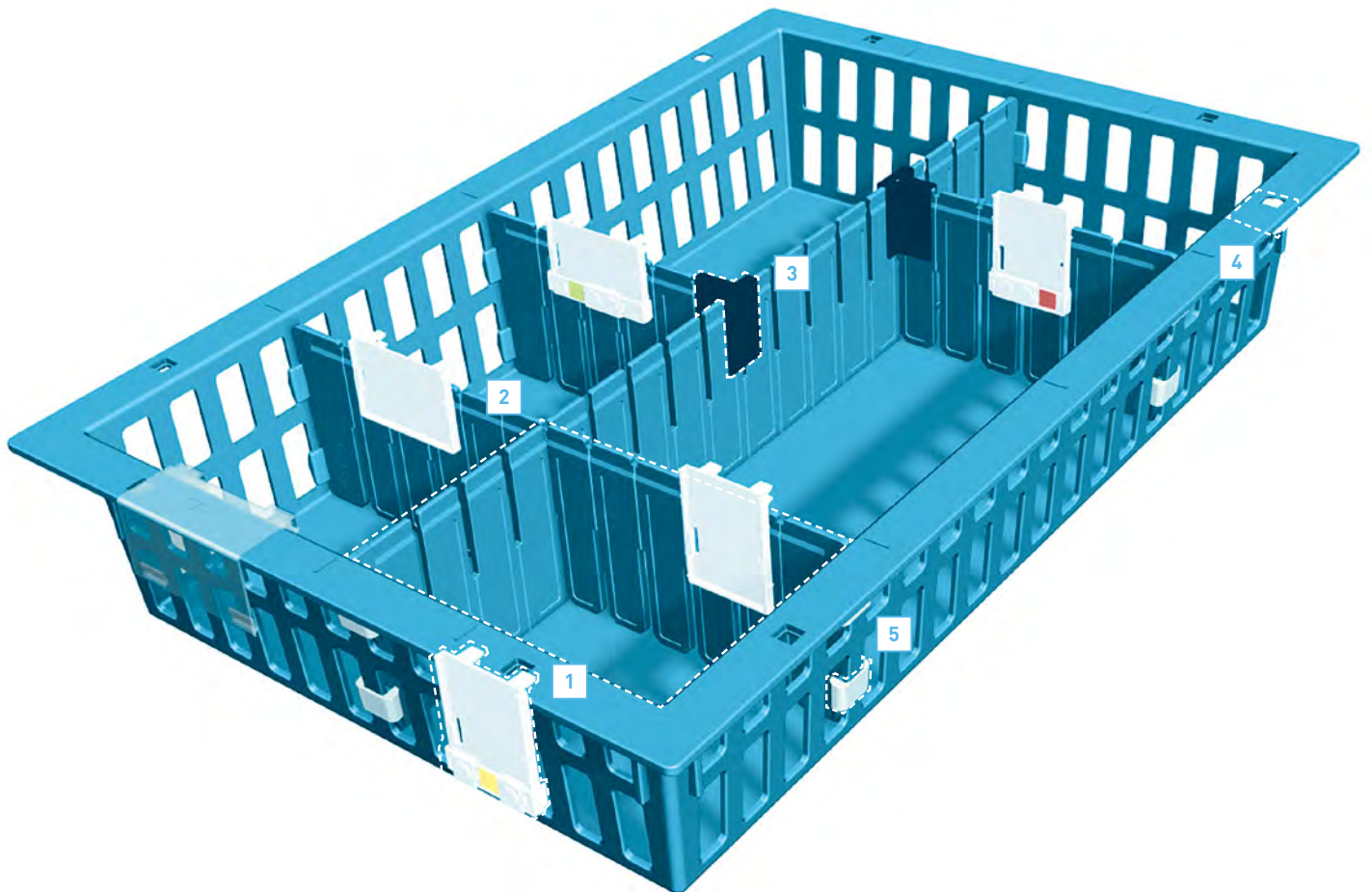

1 Label holder



Label holder

No.	Page	Designation
1	23	Label holder (ABS)

2 Divider

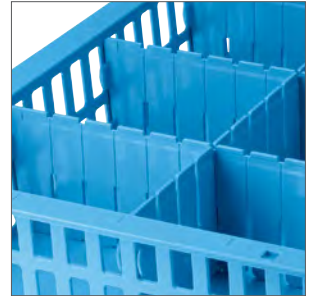
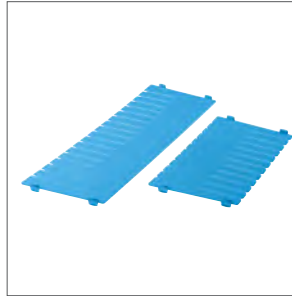

Dividers for modules and modular baskets

No.	Page	Designation
2	from 16	Divider for modules and modular baskets (ABS)

3 T-piece

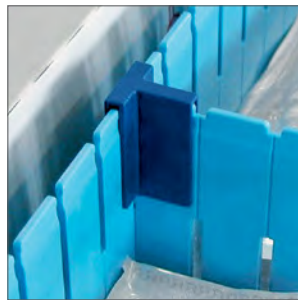
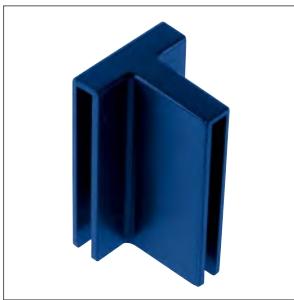

T-piece as connector

No.	Order no.	Designation	Dimensions, L × W × H, approx. mm
3	46022	T-shaped connector (ABS)	47 × 26 × 28

4 Safety stop system



Safety stop system, white/grey, one-piece

No.	Order no.	Designation
4	46026	Safety stop system, white/grey, one-piece (ABS)

5 Divider fixing



Divider fixing

No.	Order no.	Designation	Dimensions, L × W × H, approx. mm
5	46502	Divider fixing, plastic	22 × 15 × 9

Intelligent, innovative and efficient: The ZARGES labelling system.



Label clip

A seamless and optimised ordering process is only possible with the help of simple and intelligent labelling.

- ▶ The clip, which can also be retrofitted, is an ideal addition to our existing labelling system. An innovative further development of our existing product range.
- ▶ All label holders can be inserted with and without a clip.

With a simple sliding movement, the “traffic light system” indicates when new stock is required. The filling level of the KANBAN container is displayed and the order status visually recorded. **Utility-model patent protected.**



Green: sufficient quantity of the article in stock.



Yellow: article is ordered/order recorded.



Red: re-order article.

Optimum supply guaranteed: Labelling.



Label holder, vertical

Order no.	Designation	Dimensions, L x W x H, approx. mm
46551	Can be inserted in slots, clipped on to module edge and dividers	44 x 14 x 63

Matching label holder plate: 46025



Label holder, crossways

Order no.	Designation	Dimensions, L x W x H, approx. mm
46552	Can be inserted in slots, clipped on to module edge and dividers	65 x 15 x 42

Matching label holder plate: 46025



Adhesive labels in various colours for 46025

Order no.	Colour	Sheet	Packaging unit	Dimensions, W x H, approx. mm
46221	White			
46222	Blue	25 labels on DIN A4	250 sheets	37 x 55
46223	Yellow			
46224	Red			



Label clip, vertical

Order no.	Designation	Dimensions, L x W x H, approx. mm
46553	Label clip, vertical (traffic light system)	48 x 11 x 14



Label clip, crossways

Order no.	Designation	Dimensions, L x W x H, approx. mm
46554	Label clip, crossways (traffic light system)	68 x 11 x 14

Paper label for 46023

Order no.	Colour	Sheet	Packaging unit	Dimensions, W x H, approx. mm
46225	White	14 labels on DIN A4	250 sheets	80 x 40

Label holder plates (PS)

Order no.	Designation	Dimensions, L x W, approx. mm
46025	Fits 46551 and 46552	60 x 40



Label holder (PC), transparent, for paper labels

Order no.	Assembly	Dimensions, L x W x H, approx. mm
46023	clips onto upper edge of the modules	80 x 37 x 44



Label strip for mounting on inside of door

Order no.	Designation	Dimensions, L x W x H, approx. mm
46080	Anodised aluminium	330 x 20 x 3
46081	Anodised aluminium	530 x 20 x 3



Label strip for mounting on inside of door

Order no.	Designation	Dimensions, L x W x H, approx. mm
46582	Self-adhesive, transparent	350 x 3 x 25

Transparent sleeve

Order no.	Designation	Dimensions
46220	Self-adhesive	DIN A4

ZARGES cabinet systems.

With the complete ZARGES storage system, medical expendables and pharmacy goods are stored optimally and in compliance with the most stringent hygiene requirements, but are always to hand when required.



Ideal solutions for an ergonomic work process

1 Support systems. Such as support walls, telescopic rails and multifunction insert rails allow easy access. See from page 28. **2 Cupboard accessories.** The well thought-out cabinet system comprises a wide range of accessories, e. g. holders for catheter storage, wire mesh compartments, notched rails for telescopic drawers, recyclables collection bin, shelf compartments. See from page 32. **3 Cupboard units.** The modular ZARGES cabinet system can be put together by combining



individual cupboard units, e.g tall cupboard, lower cabinet, wall cabinet and top cupboard. See from page 38. **4 Material/surface.** ZARGES offers a wide variety of materials and surfaces for individual applications. See from page 43. **5 Modules and modular baskets.** ZARGES ISO modules and modular baskets. See from page 16. **6 Labelling system.** The ZARGES labelling system. See from page 22.

Front options for tall cupboards.



Closed door

Two options available:

- ▶ Plastic-coated chipboard E1, 19 mm thick, coated on both sides with MF resin in accordance with EN 14322.
- ▶ Plastic board with black core.
- ▶ ABS sealing tape on cabinet body.



Glass door

- ▶ Safety glass.
- ▶ Glass frame in KS or VKS.
- ▶ ABS sealing tape on cabinet body.



Rolling tambour door

- ▶ Space-saving opening.
- ▶ Material: plastic PP.
- ▶ Deep-drawn, consists of one part.
- ▶ Can be removed for cleaning without the use of tools.
- ▶ Colour: Light grey.

Sturdy, functional, universal: Support walls for simple assembly.



Support wall for tall cupboard, straight

- ▶ ABS, white/grey.
- ▶ Designed for drawer stop.
- ▶ Injection moulding.
- ▶ One version, identical on left / right.
- ▶ Load bearing capacity of up to 20 kg per insert level.
- ▶ Hygienic border between support wall and cabinet body.
- ▶ Installation with and without holding/angle strip.
- ▶ Minimal assembly and disassembly work required if secured with holding and angle strips.
- ▶ With 6 ribs/support beads per segment.

Support wall for tall cupboard with tilt function

- ▶ ABS, white/grey.
- ▶ Designed for drawer stop.
- ▶ Injection moulding.
- ▶ One version, identical on left / right.
- ▶ Load bearing capacity of up to 20 kg per insert level.
- ▶ Hygienic border between support wall and cabinet body.
- ▶ Installation with and without holding/angle strip.
- ▶ Minimal assembly and disassembly work required if secured with holding and angle strips.
- ▶ With 6 ribs/support beads per segment.
- ▶ Tilt function to approx. 25°.

Order no.	Designation	Dimensions, D × H, mm
46196	ABS support wall, straight, rail for ISO 618	364 × 300
46198	ABS support wall, rail for ISO 418	564 × 300

Order no.	Designation	Dimensions, D × H, mm
46197	ABS support wall with tilt function for ISO 618	364 × 300
46199	ABS support wall with tilt function for ISO 418	564 × 300

Required mounting elements

Order no.	Designation	Fits
46517	Holding strip, length 900 mm	3 segments
46518	Angle strip, length 900 mm	3 segments
46519	Holding strip, length 600 mm	2 segments
46520	Angle strip, length 600 mm	2 segments

The ideal support wall for wall units.



Support wall for wall cabinet

- ▶ ABS, white/grey.
- ▶ Designed for drawer stop.
- ▶ Deep-drawn.
- ▶ One version, identical on left / right.
- ▶ Hygienic border between support wall and cabinet body.



Order no.	Designation	Dimensions, L × W, mm
46120	ABS support wall with tilt function	517 × 262
46049	ABS support wall, straight	497 × 262

Roller rail for support wall

- ▶ POM, white/grey.
- ▶ Designed for drawer stop.
- ▶ Injection moulding.
- ▶ Set consists of a right and left rail.
- ▶ Equipped with easy-running castors.
- ▶ Can be mounted on standard support walls.



Order no.	Designation	Dimensions, L × W × H, mm
46485	Roller rail for support wall Set consists of a right and left rail	300 × 35 × 27 mm

Quick and easy access: Telescopic rails.



Telescopic rails for ISO standard cabinets, can be hooked on in various positions

- ▶ Galvanised steel.
- ▶ Fully extendible on precision rail with double bearings.
- ▶ Pins for direct mounting of the modules, modular baskets and shelf compartments.
- ▶ Engagement of the rail in end position, locking.
- ▶ 2 hook-on tabs for each telescopic rail for hooking into notched rails.



Telescopic rails for ISO standard cabinets for fixed installation

- ▶ Galvanised steel.
- ▶ Fully extendible on precision rail with double bearings.
- ▶ Direct accommodation of the modular baskets and modules with adapters which are required additionally.
- ▶ Automatic engagement of the rail in end position, cushioned with soft closing.
- ▶ 2 fastening tabs for each telescopic rail.

Telescopic rails, can be hooked on in various positions

Order no.	Designation	Dimensions, L, approx. mm
46346	Telescopic rail, right	600
46347	Telescopic rail, left	600
46344	Telescopic rail, right	400
46345	Telescopic rail, left	400
46368	Telescopic rail, right, soft closing	600
46369	Telescopic rail, left, soft closing	600
46366	Telescopic rail, right, soft closing	400
46367	Telescopic rail, left, soft closing	400

Telescopic rails, fixed

Order no.	Designation	Dimensions, L, approx. mm
46218	Telescopic rail, right, soft closing	600
46219	Telescopic rail, left, soft closing	600
46216	Telescopic rail, right, soft closing	400
46217	Telescopic rail, left, soft closing	400

Telescopic rails, can be hooked on in various positions and pulled out on both sides

Order no.	Designation	Dimensions, L, approx. mm
46118	Telescopic rail, right/left	600



Notched rails for variable installation of telescopic rails and multifunction insert rails

- ▶ Galvanised steel.
- ▶ Protected against corrosion.
- ▶ Insertion slots at intervals of 25 mm.
- ▶ Permanently screwed to the cupboard inside wall.

Notched rails for telescopic rail

Order no.	Designation	Dimensions, L, approx. mm
46522	8 items for 1 tall cupboard	900
46521	4 items for 1 lower cabinet	600

Practical and easy to install: Accessories.



Adapter for fixed telescopic rails

- ▶ Galvanised steel.
- ▶ Telescopic rails for fixed installation have no fitted pins.
- ▶ Adapters are required to accommodate accessories.



Plastic mount for wire mesh compartment and catheter magazine

Order no.	Material	Dimensions, L, mm
46254	plastic, white	60



Securing clip for tube holder and catheter drawer

Order no.	Material	Dimensions, L, mm
46129	plastic, white	60

Order no.	Implementation	Designation	Dimensions, L, mm
46159	right	For 46218	600
46160	links	For 46219	600
46161	right	For 46216	400
46162	links	For 46217	400



Multifunctional insert rails for wall units

- ▶ Insert rail: Aluminium, U-profile, anodised.
- ▶ End caps: Plastic.
- ▶ Longitudinally adjustable by moving the end caps on the insert rail.
- ▶ Can be hooked onto notched rails.
- ▶ Can be suspended in 3 positions: horizontally, 15° and 30°.



Horizontal position



15° position



30° position

Order no.	Designation	Dimensions, L, approx. mm
46234/46237	2 insert rails	400
46235/46236	2 insert rails	600
355908/355909	2 insert rails	310

The clever system for storing catheters.



Catheter racks

- ▶ Stainless steel CNS.
- ▶ Other versions and sizes on request.

Order no.	Designation	Dimensions, L × W × H, approx. mm
46046	Catheter racks	150 × 100 × 280
46047	Catheter racks	150 × 100 × 480
46048	Catheter racks	150 × 100 × 550

Module frame for catheter racks

- ▶ For upright storage.
- ▶ For 8 catheter racks.
- ▶ Suitable for telescopic rail.

Order no.	Designation	Dimensions, L × W × H, approx. mm
46605	Module frame for catheter racks, ABS plastic	600 × 400 × 100
46606	Module frame for catheter racks, ABS plastic	400 × 600 × 100



Catheter magazine ISO

- ▶ Stainless steel CNS, electropolished.
- ▶ For upright storage.
- ▶ Suitable for telescopic rail.
- ▶ Incl. 1 lengthwise and 2 crosswise dividers.
- ▶ Installed with plastic mount 46254.

Order no.	Designation	Dimensions, L × W × H, approx. mm
46045	Catheter magazine ISO, with flexible subdivision	600 × 400 × 600

Further solutions for catheter storage.



Catheter drawer, steel, powder-coated

- ▶ For suspended storage.
- ▶ Suitable for telescopic rail.
- ▶ Installed with securing clip 46129.

Order no.	Designation	Dimensions, L × W, approx. mm
46511	Catheter drawer	600 × 400
46512	Catheter drawer	400 × 600



Tube holder

- ▶ For suspended storage.
- ▶ Suitable for telescopic rail.
- ▶ Installed with securing clip 46129.

Order no.	Designation	Dimensions, L, approx. mm
46507	Tube holder, steel, powder-coated	600
46508	Tube holder, steel, powder-coated	400
46509	Tube holder, stainless steel	600
46510	Tube holder, stainless steel	400



ABS catheter holder

- ▶ Material: ABS.
- ▶ Suitable for upright storage.
- ▶ Consisting of: 2 × modular basket 46005, 2 × lengthwise and crosswise divider, connecting elements.
- ▶ Suitable for telescopic rail and support wall.

Insert depth, 600 mm

Order no.	Designation	Dimensions, L × W × H, approx. mm
345515	Catheter holder, 600 long	600 × 400 × 825
345514	Catheter holder, 600 long	600 × 400 × 600

Insert depth, 400 mm

Order no.	Designation	Dimensions, L × W × H, approx. mm
363810	Catheter holder, 400 long	400 × 600 × 600

Organisation made easy: Cupboard accessories.



Shelf compartment

- ▶ Suitable for support wall and notched rail.

Order no.	Designation	Dimensions, L × W × H, approx. mm
46100	Shelf compartment*	600 × 400 × 10
46101	Shelf compartment*	300 × 400 × 10
46486	Shelf support, 4 per shelf compartment	-
46212	Shelf compartment, plastic	600 × 400 × 10

* MF-resin-coated wood fibreboard

Order no.	Designation	Dimensions, L × W × H, approx. mm
46213	Shelf compartment, Solid plastic with drilled holes for telescopic drawers and compatible with drawer stop	600 × 400 × 10



Wire mesh compartment

- ▶ Chrome nickel steel 1.4301, electropolished.
- ▶ Frame wire: 6 mm.
- ▶ Grid wire: 3 mm.
- ▶ Mesh size: 25 × 25 mm.
- ▶ Suitable for sterile containers.
- ▶ Installed with plastic mount 46254.

Order no.	Designation	Dimensions, L × W × H, approx. mm
46550	CNC wire mesh compartment, insertable lengthwise and crosswise incl. plastic holders for telescopic drawer, peripheral safety frame	600 × 400 × 19

ISO frame for drawers

- ▶ Powder-coated steel.
- ▶ For telescopic drawer.
- ▶ To accommodate ISO-standard modules.
- ▶ Installation without plastic mount.

Order no.	Designation	Dimensions, L, approx. mm
46188	For telescopic drawer 46218/46219	600
46189	For telescopic drawer 46216/46217	400

Ideal solutions for everyday tasks: Cupboard accessories.



Recyclables collection bin

- ▶ Anodised aluminium.
- ▶ 2 drop handles.

Order no.	Designation	Dimensions, L × W × H, approx. mm
46084	Recyclables collection bin, anodised aluminium	337 × 301 × 516



Frame for suspension files

- ▶ Anodised aluminium.
- ▶ For DIN A4 suspension file.
- ▶ Suitable for variable and fixed telescopic rails.

Order no.	Designation	Dimensions, D, approx. mm
46505	Frame for suspension files, anodised aluminium	600
46506	Frame for suspension files, anodised aluminium	400



Medication refrigerator and froster

- ▶ Free-standing, can also be installed in modular cupboards.
- ▶ Various models in accordance with customer requirements.
- ▶ Complies with the relevant regulations.
- ▶ Price on request.



Safe for anaesthetics (BTM)

All BTMs meet the requirements of the safety levels prescribed by law (delivery includes mounting material and keys). On request, BTMs can be installed in modular cupboards.

- ▶ Special sizes available, e.g. with integrated modular system.
- ▶ Price on request.
- ▶ Safety category on request.

Optimally planned: ZARGES cabinet systems.



For operational and nursing areas: Planning, coordination, processing and execution

► Spatial planning

We calculate the exact storage capacity needed on the basis of consumption analyses and design the storage facilities to meet the requirements with regard to hygiene and ergonomics.

► Costing

Taking into account the existing storage capacities and all logistics processes, we determine and calculate the actual storage media requirements, both with regard to quantities and cost, and submit them for approval.

► Drafting and design

All materials and the design are individually coordinated and tailored to the requirements of your facility on the basis of the specific logistics processes there.

Where there are special requirements (fire protection, radiation protection etc.), we will find corresponding solutions while still ensuring optimised logistics planning.



► Schedule

We supervise the conversion measures and on request, coordinate the technical processes.

► Full equipment

If desired, we can supply the logistics equipment as well as design the entire working area in accordance with ergonomic principles.

► Service

Thanks to our supra-regional network of specialist dealers and partners, we are in a position to carry out all structural measures flexibly and promptly. All standard furniture can be delivered at short notice. In the case of projects, delivery is effected to agreed deadlines.

ZARGES height units.

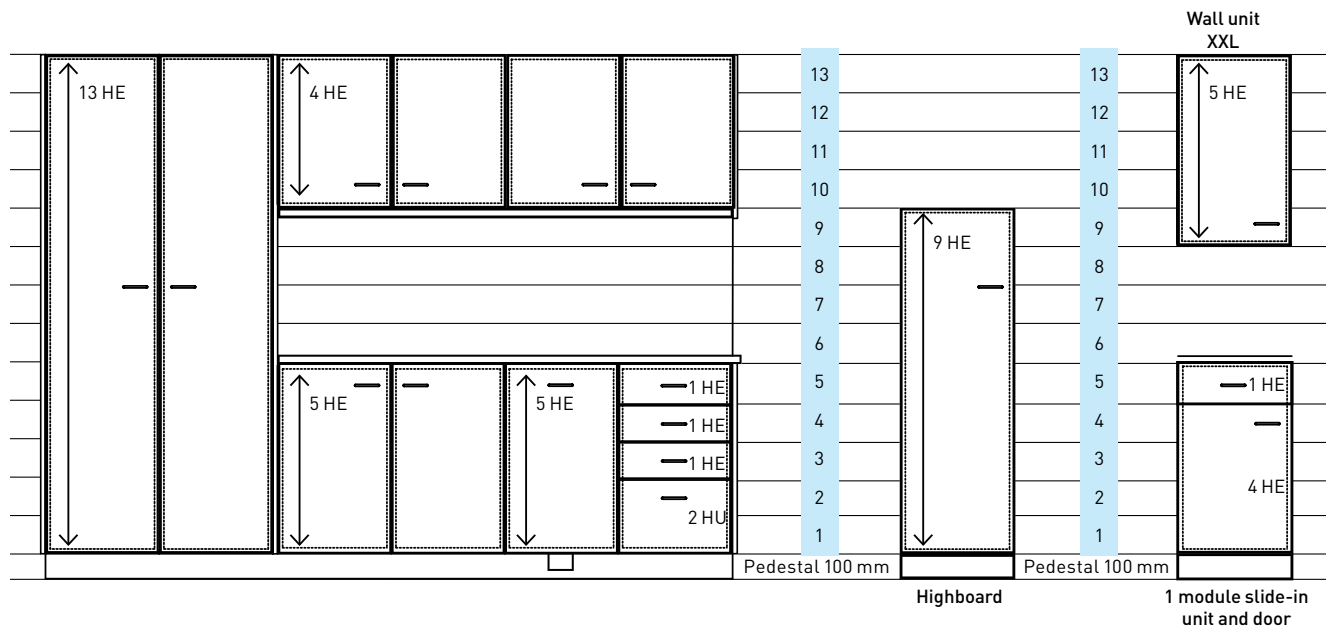

→ Height units Cabinet examples

The ZARGES ISO modular cupboards are subdivided into front height units (HE). 1 HE = 154 mm.

These height units refer to the height of the cupboard body itself, while in the case of articles which stand on the floor, 100 mm must be added for the pedestal.

Advantages

- ▶ Individual cupboard configurations using the "ZARGES grid".
- ▶ Reliable planning of the cupboard body heights.

The ZARGES height units enable you to put together individual configurations of standard cupboards to comply with the specific requirements of the user.

Examples

- 1 HE = max. 100 mm modular basket height
- 2 HE = max. 200 mm modular basket height
- 3 HE = safes for anaesthetics (BTMs)
- 4 HE = fitted medication froster
- 5 HE = fitted medication refrigerator
- 9 HE = catheter racks for upright storage of catheters
- 11 HE = catheter drawer for suspended catheter storage

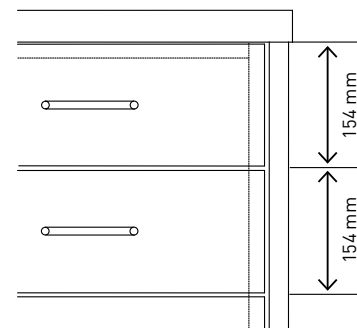

Tall cupboards.

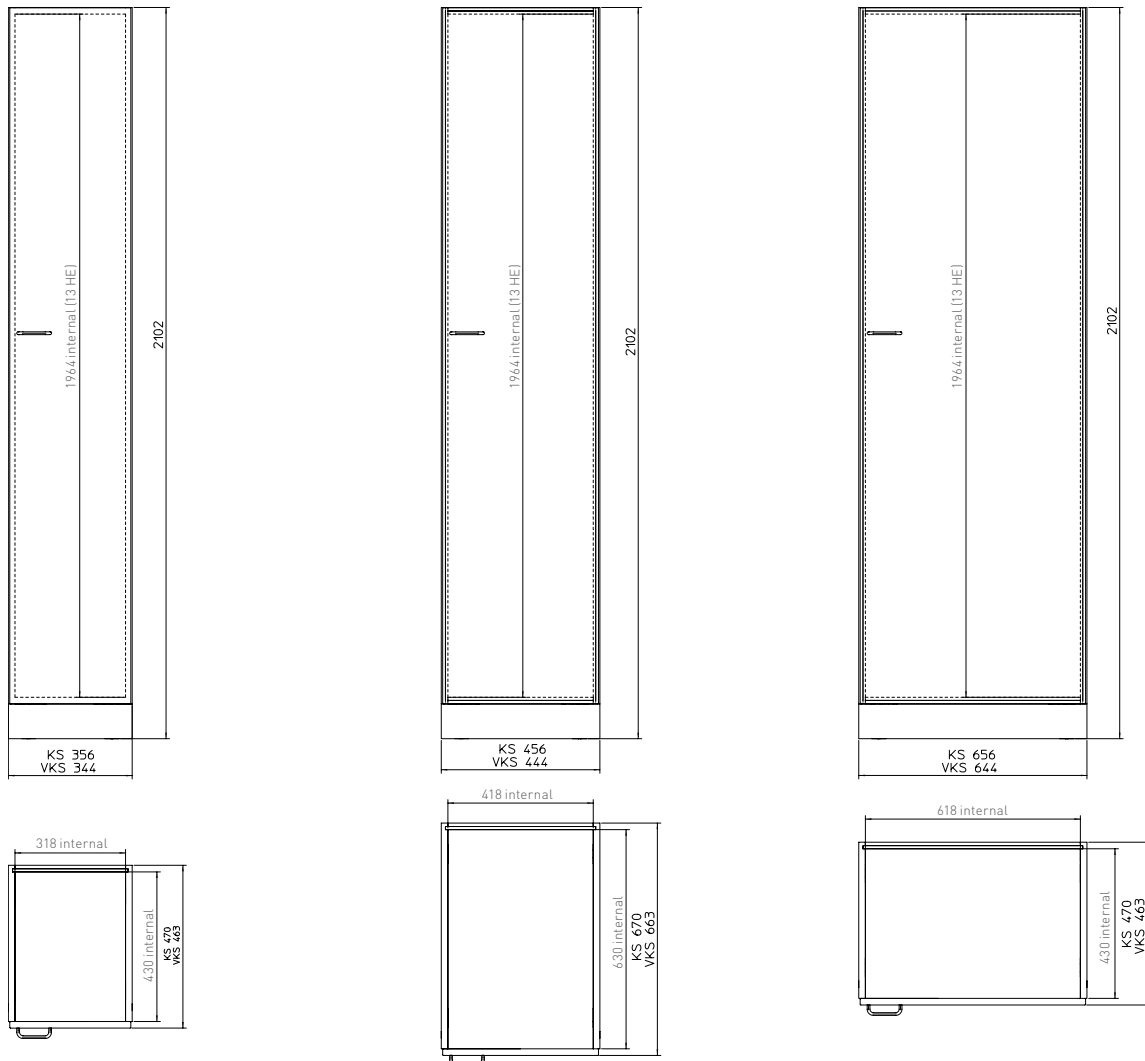

Cupboard units 1: ISO tall cupboards

Available in wood (KS) and with plastic body (VKS) in ISO systems ISO 318, ISO 418 and ISO 618.

Designed to be equipped with ISO modules

- ▶ Support walls.
- ▶ Telescopic rails, fixed installation or on notched rails.

Available in versions:

- ▶ Open.
- ▶ Door in KS or VKS.
- ▶ Glass-framed door (ESG glass).
- ▶ Aluminium and plastic rolling tambour doors.
- ▶ Various locking systems possible.

We design and produce tall cupboards as refrigerator surrounds or with integrated safe for anaesthetics individually to your specifications after selection of the electrical appliances, also in combination with our ISO modular system.

Abbreviations:

KS: Plastic-coated

VKS: Plastic

Lower cabinets.

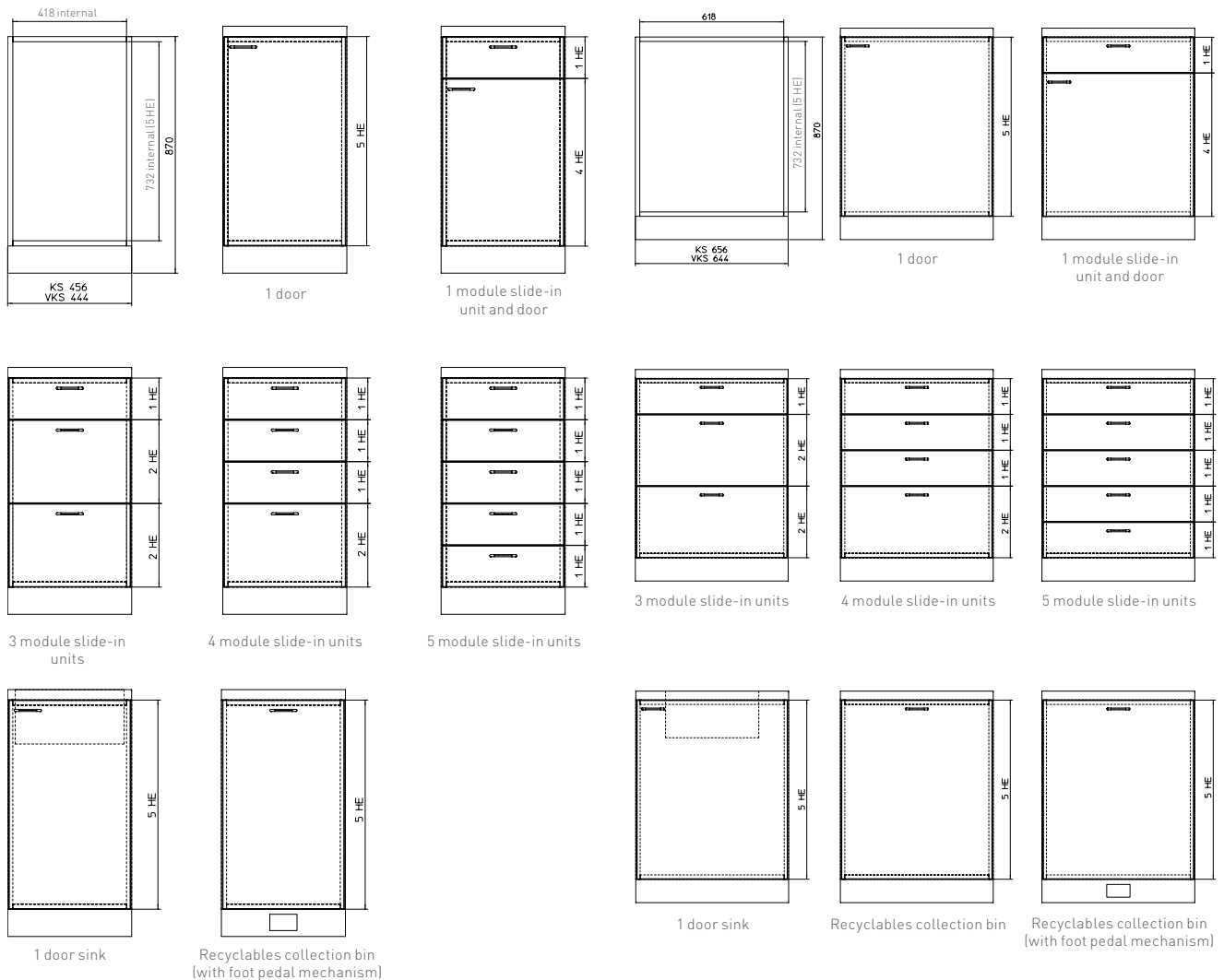

Cupboard units 2: ISO lower cabinets

Available with wood (KS) and plastic body (VKS) in ISO systems ISO 418 and ISO 618.

Designed to be equipped with ISO modules

- ▶ Support walls.
- ▶ Telescopic rails (fixed).
- ▶ Module frame on telescopic rails (slide-in unit).
- ▶ Notched rails.

Available with various fronts:

- ▶ Open.
- ▶ Door in KS.
- ▶ Door in VKS.
- ▶ Aluminium glass-framed door (ESG glass).
- ▶ Aluminium and plastic rolling tambour doors.

Lower cabinets, e.g. as refrigerator surrounds, are planned and manufactured individually by us to your specifications after selection of the electrical appliances.

Lower cabinets are also available as:

- ▶ Sink base units.
- ▶ Lower cabinet recyclables collection system (with foot pedal mechanism).

All lower cabinets in ISO-618 width are also available with two doors.

All cupboards can be supplied with a variety of locking systems.

Wall units.

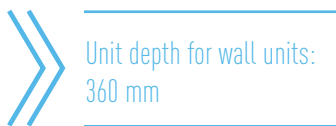
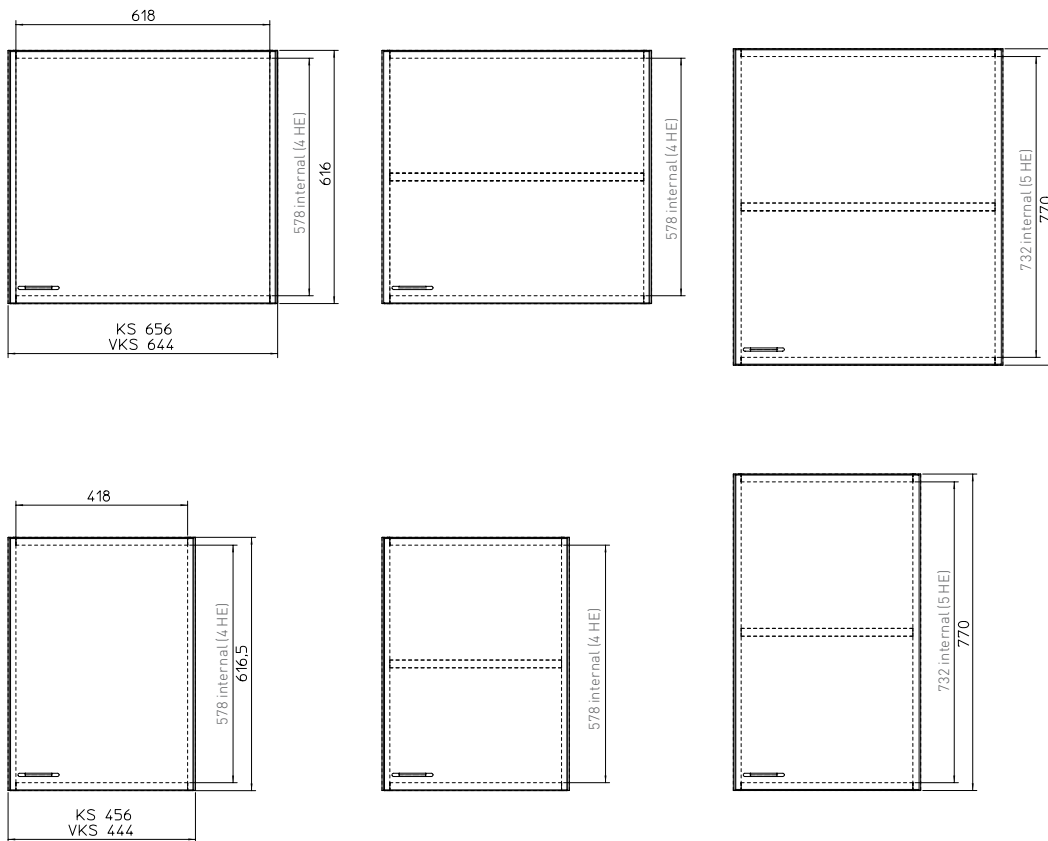

Cupboard units 3: ISO wall units

Available with wood (KS) and plastic body (VKS) in ISO systems ISO 418 and ISO 618.

Designed to be equipped with ISO modules

- ▶ Support walls.

Available with various fronts:

- ▶ Open.
- ▶ Door in KS.
- ▶ Door in VKS.
- ▶ Aluminium glass-framed door (ESG glass).
- ▶ Aluminium and plastic rolling tambour doors.

We can also supply wall units with shelf compartments on stainless steel shelf support rails. All wall units in ISO 618 with shelf compartments.

We can also plan top mounted cupboards as cupboards with shelf compartments individually for you to suit the specified room height.

As an option, we can also plan, supply and install our own aluminium rail system ladder.

Top mounted cupboards.



You can find accessories for rail system ladders and hook-on ladders on page 162.

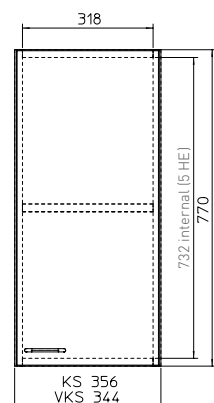

1 shelf compartment

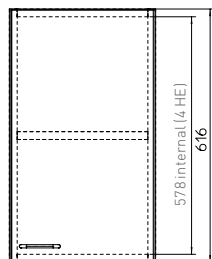

1 shelf compartment

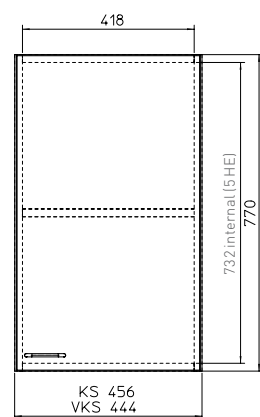
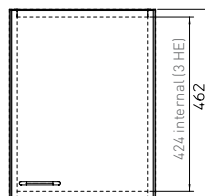

1 shelf compartment

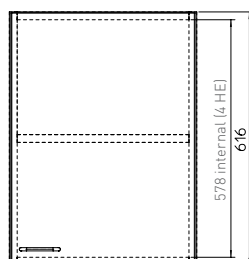

1 shelf compartment

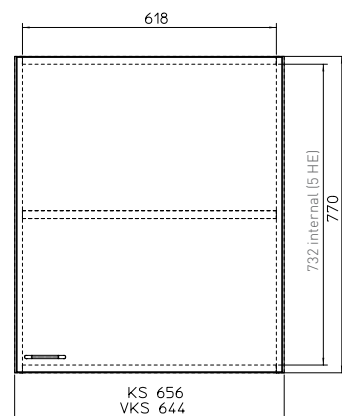
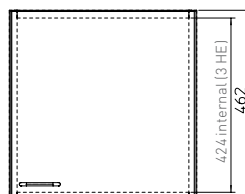

1 shelf compartment

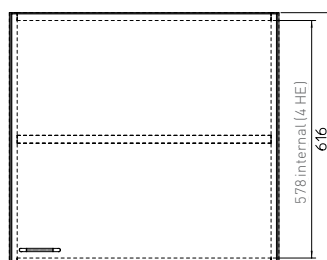

1 shelf compartment

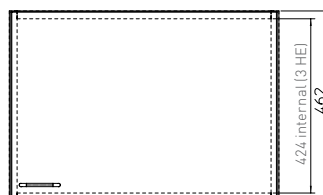

Cupboard units 4: ISO top mounted cupboards

Available in wood (KS) and plastic (VKS) in ISO systems ISO 318, ISO 418 or ISO 618 or after adjustment to the room height.

Designed to be equipped with ISO modules

- ▶ Support walls.
- ▶ Shelf compartment on shelf supports.

Available in versions:

- ▶ Open.
- ▶ Door in KS or VKS.
- ▶ Glass-framed door.
- ▶ Various locking systems possible.

Top mounted cupboards in ISO 618 are also available with two doors.

Railing front (1 HE) recommended.

ZARGES handles, fittings and locking systems.

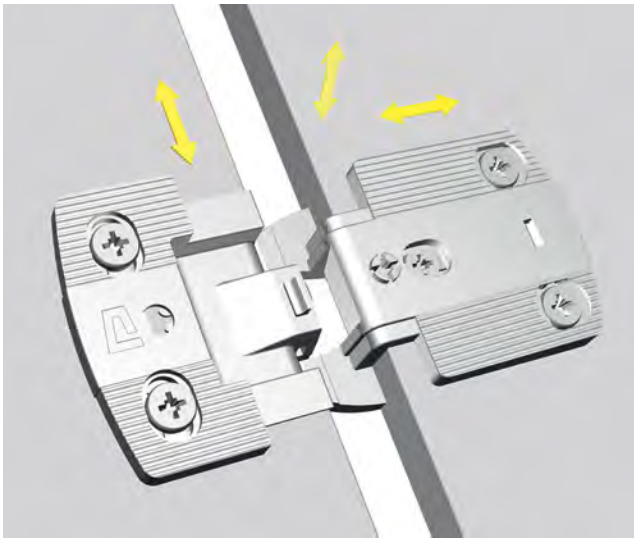

Hinges

Special flat hinges – special hinges

- ▶ For wooden doors (material thickness 19 mm).
- ▶ For plastic doors (material thickness 12 mm).

Flat construction – suitable for modular systems

- ▶ Robust all-metal design in precision die-cast zinc.
- ▶ With automatic shutting.
- ▶ Hardened, secured steel axis in maintenance-free plastic bearings.
- ▶ Roll thickness 5 mm, roll length 47 mm.
- ▶ Corner and centre joint 6 mm.
- ▶ Opening angle up to 240°.
- ▶ No space between door and cupboard at 140° opening angle.
- ▶ Can be adjusted in three directions.
- ▶ Door-support adjustment in side section +2/-1 mm.
- ▶ Door height adjustment in head section +2/-2 mm.
- ▶ Via excentric in each case.
- ▶ Depth adjustment via side section +2/-1 mm.

Handles



U-shaped handle

- ▶ Length 106 mm, Ø10 mm.
- ▶ Steel, matt nickel-plated.

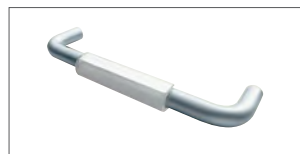

Labelling clip

- ▶ For 10-mm round-rod handles.
- ▶ Size 55×9 mm.
- ▶ Material/surface: plastic, transparent.



Locking system SYMO 3000 (standard locking)

SYMO 3000 is a unique furniture locking system manufactured by Häfele. No tools required, quick and easy to fit, maximum flexibility with minimum effort.

- ▶ Lock plans can be changed in minimum time and cost. All you need to do is replace the cylinder core (no tools required). The lock and the furniture itself remain untouched.
- ▶ Reliable locking is essential so we use the SYMO 3000 STW cylinder with tumbler pins in our entire range. Its design allows up to 20,000 different locking combinations.
- ▶ SYMO 3000 allows the realisation of both simple and highly complex locking systems. The lock plan is realised simply by inserting the cylinder core, which can be done at any time, independent of manufacture, delivery or assembly of the furniture. The lock plan can be extended and modified at any time: This is done simply by replacing the SYMO 3000 cylinder cores – a simple and inexpensive solution.



Further stirrup-type handles, bar stirrup-type handles, inset handles and accessories on request.

ZARGES colour range KS and VKS.

Plastic-coated (KS)

Body

- ▶ Plastic-coated chipboard E1.
- ▶ Sides and floors 19 mm, rear wall 8 mm thick, coated on both sides with MF resin in accordance with DIN 68765 and EN 14322.

Fronts, panels and visible surfaces

- ▶ Plastic-coated chipboard E1, 19 mm thick, coated on both sides with MF resin in accordance with DIN 68765 and EN 14322.

Edges

- ▶ Corners and edges rounded with a radius of 2 mm.
- ▶ Alternatively, ABS sealing edge (double-band).

Pedestal

- ▶ Raw particle board V100 (waterproof), 19 mm thick, covered with HPL, decor as body material or CNS (stainless steel).
- ▶ Lower edge with sealing profile, on request additional sealing between lower edge and floor.

Worktops

- ▶ Postforming boards, HPL-coated, 38 mm thick.
- ▶ Decor according to colour card.
- ▶ On request, solid surface worktops (e.g. Corian) or CNS (stainless steel).

Examples, KS



Examples of fronts



Plastic (VKS)

Body

- ▶ Plastic board with black core.
- ▶ Sides and floors 13 mm thick, rear wall 6 mm with black core.

Fronts, panels and visible surfaces

- ▶ 13-mm plastic board with black core.
- ▶ Plain standard decor: white, light grey.
- ▶ On request with front sealing band.

Edges

- ▶ Milled and polished, rounded with a radius of 2 mm.

Pedestal

- ▶ 13-mm plastic board, decor as for body.
- ▶ Fitted by clipping on.
- ▶ Lower edge with sealing profile, on request with additional sealing between lower edge and floor.

Worktops

- ▶ 38-mm postforming board, HPL-coated.
- ▶ Decor according to colour card.
- ▶ On request, solid surface worktops (e.g. Corian) or CNS (stainless steel).

For shelf compartments, the cupboards are fitted with continuous metal shelf support rails, 5 × 15 mm.

Examples of worktops



Further colours with materials on request.

Standard cupboard configurations for medication.

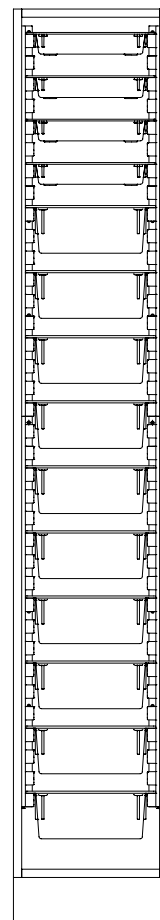
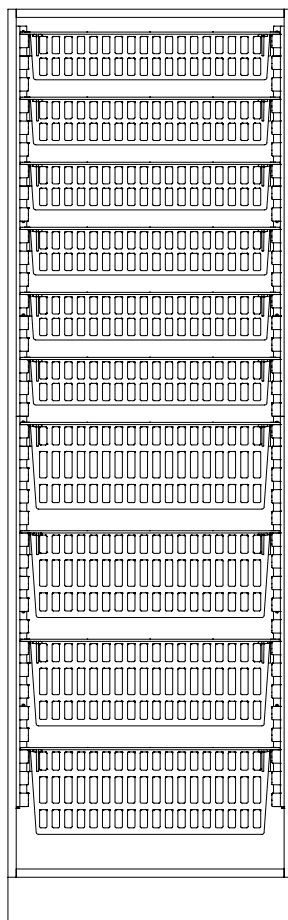
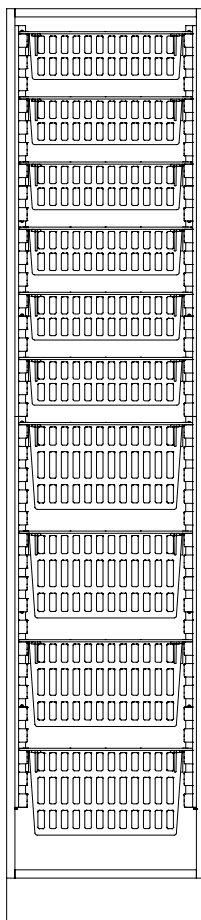

ISO standard HS ISO 418 MHS418/13 HE

Dimensions, W × H × D, mm	Quantity
456 × 2,102 × 670	1

Order no.	Designation	Quantity
46004	PC module 600 × 400 × 100	2
46042	PC divider 600 × 100	2
46043	PC divider 400 × 100	2
46005	ABS modular basket 600 × 400 × 100	4
46029	Divider 600 × 100	5
46030	Divider 400 × 100	10
46000	ABS modular basket 600 × 400 × 200	4
46027	Divider 600 × 200	3
46028	Divider 400 × 200	6
46026	Safety stop system	20
46022	T-piece	2
46502	Divider fixing – POM	16
46199	Support wall, tilt	4
46198	Support wall, straight	8
46517	Retaining strip, 900 mm	4
46518	Angle strip, 900 mm	4

ISO standard HS ISO 618 MHS618/13 HE

Dimensions, W × H × D, mm	Quantity
656 × 2,102 × 470	1

Order no.	Designation	Quantity
46004	PC module 600 × 400 × 100	2
46042	PC divider 600 × 100	2
46043	PC divider 400 × 100	2
46005	ABS modular basket 600 × 400 × 100	4
46029	Divider 600 × 100	5
46030	Divider 400 × 100	10
46000	ABS modular basket 600 × 400 × 200	4
46027	Divider 600 × 200	3
46028	Divider 400 × 200	6
46026	Safety stop system	20
46022	T-piece	2
46502	Divider fixing – POM	16
46197	Support wall, tilt	4
46196	Support wall, straight	8
46517	Retaining strip, 900 mm	4
46518	Angle strip, 900 mm	4

ISO standard HS ISO 318 MHS318/13 HE

Dimensions, W × H × D, mm	Quantity
356 × 2,102 × 470	1

Order no.	Designation	Quantity
46007	PC module 300 × 400 × 50	4
46038	PC divider 400 × 50	4
46039	PC divider 300 × 50	4
46006	PC module 300 × 400 × 100	10
46036	PC divider 400 × 100	10
46037	PC divider 300 × 100	10
46026	Safety stop system	26
46197	Support wall, tilt	4
46196	Support wall, straight	8
46517	Retaining strip, 900 mm	4
46518	Angle strip, 900 mm	4

Standard cupboard configurations for medication.

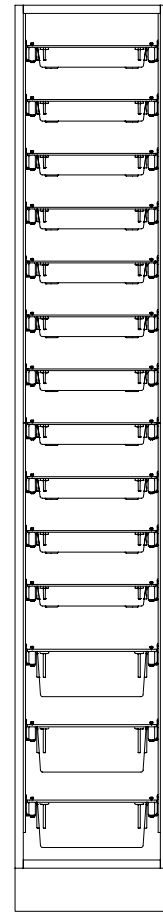
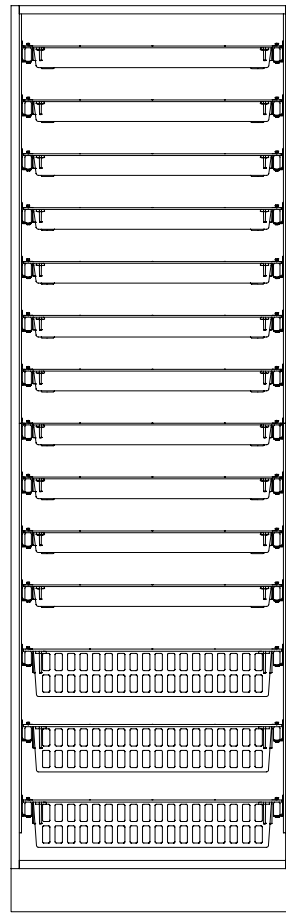
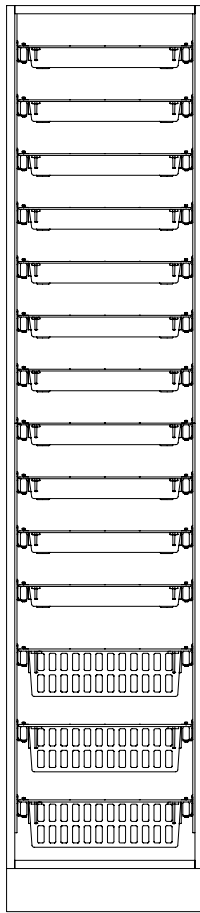

ISO standard HS ISO 418 AHS418/13 HE

Dimensions, W × H × D, mm	Quantity
456 × 2,102 × 670	1

Order no.	Designation	Quantity
46010	PC-Medi module 600 × 400 × 50	11
46031	PC divider 600 × 50	22
46032	PC divider 400 × 50	66
46004	PC module 600 × 400 × 100	3
46042	PC divider 600 × 100	6
46043	PC divider 400 × 100	12
46022	T-piece	10
46522	Notched rail 900	8
46346	Telescopic rail, hook-on, 600 mm, right	14
46347	Telescopic rail, hook-on, 600 mm, left	14

ISO standard HS ISO 618 AHS618/13 HE

Dimensions, W × H × D, mm	Quantity
656 × 2,102 × 470	1

Order no.	Designation	Quantity
46010	PC-Medi module 600 × 400 × 50	11
46031	PC divider 600 × 50	22
46032	PC divider 400 × 50	66
46004	PC module 600 × 400 × 100	3
46042	PC divider 600 × 100	6
46043	PC divider 400 × 100	12
46022	T-piece	10
46522	Notched rail 900	8
46344	Telescopic rail, hook-on, 400 mm, right	14
46345	Telescopic rail, hook-on, 400 mm, left	14

ISO standard HS ISO 318 AS318/13 HE

Dimensions, W × H × D, mm	Quantity
356 × 2,102 × 470	1

Order no.	Designation	Quantity
46007	PC module 300 × 400 × 50	11
46038	PC divider 400 × 50	4
46039	PC divider 300 × 50	4
46006	PC module 300 × 400 × 100	3
46036	PC divider 400 × 100	3
46037	PC divider 300 × 100	3
46522	Notched rail 900	8
46344	Telescopic rail, hook-on, 400 mm, right	14
46345	Telescopic rail, hook-on, 400 mm, left	14

Further variant: Standard cupboard configurations for medication.

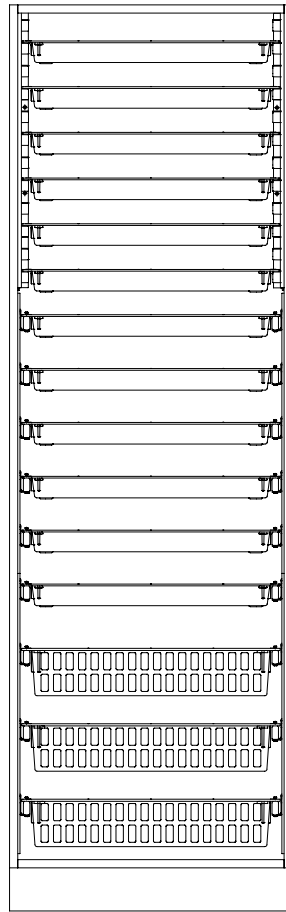
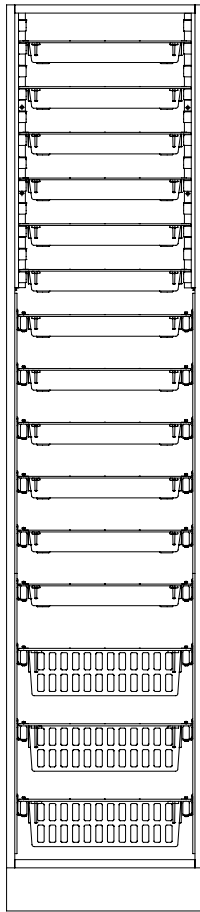

ISO standard HS ISO 418 AHS418/13 HE

Dimensions, W × H × D, mm	Quantity
456 × 2,102 × 670	1

Order no.	Designation	Quantity
46010	PC Medi module 600 × 400 × 50	12
46031	PC divider 600 × 50	24
46032	PC divider 400 × 50	72
46004	PC module 600 × 400 × 100	3
46042	PC divider 600 × 100	6
46043	PC divider 400 × 100	12
46026	Safety stop system	12
46022	T-piece	10
46199	Support wall, tilt	4
46519	Holding strips 600	2
46520	Angle strips 600	2
46521	Notched rail 600	8
46346	Telescopic rail, hook-on, 600 mm, right	9
46347	Telescopic rail, hook-on, 600 mm, left	9

ISO standard HS ISO 618 AHS618/13 HE

Dimensions, W × H × D, mm	Quantity
656 × 2,102 × 470	1

Order no.	Designation	Quantity
46010	PC Medi module 600 × 400 × 50	12
46031	PC divider 600 × 50	24
46032	PC divider 400 × 50	72
46004	PC module 600 × 400 × 100	3
46042	PC divider 600 × 100	6
46043	PC divider 400 × 100	12
46026	Safety stop system	16
46022	T-piece	10
46197	Support wall, tilt	4
46519	Holding strips 600	2
46520	Angle strips 600	2
46521	Notched rail 600	8
46344	Telescopic rail, hook-on, 400 mm, right	9
46345	Telescopic rail, hook-on, 400 mm, left	9

Standard cupboard configurations for medication.

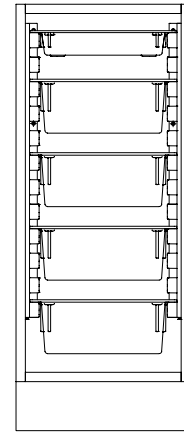
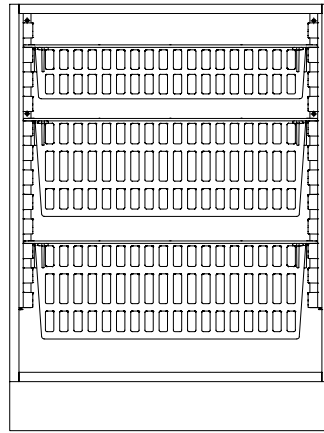
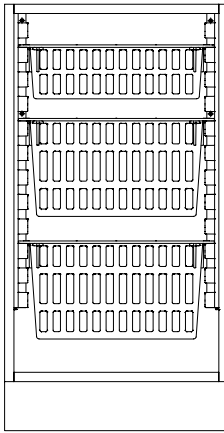

ISO standard US ISO 418 MUS418/5 HE

Dimensions, W × H × D, mm	Quantity
456 × 870 × 651	1

Order no.	Designation	Quantity
46005	ABS modular basket 600 × 400 × 100	1
46029	Divider 600 × 100	1
46030	Divider 400 × 100	2
46000	ABS modular basket 600 × 400 × 200	2
46027	Divider 600 × 200	2
46028	Divider 400 × 200	2
46026	Safety stop system	6
46022	T-piece	2
46502	Divider fixing – POM	8
46198	Support wall, straight	4
46519	Holding strip 600	2
46520	Angle strip 600	2

ISO standard US ISO 618 MUS618/5 HE

Dimensions, W × H × D, mm	Quantity
656 × 870 × 451	1

Order no.	Designation	Quantity
46005	ABS modular basket 600 × 400 × 100	1
46029	Divider 600 × 100	1
46030	Divider 400 × 100	2
46000	ABS modular basket 600 × 400 × 200	2
46027	Divider 600 × 200	2
46028	Divider 400 × 200	2
46026	Safety stop system	6
46022	T-piece	2
46502	Divider fixing – POM	8
46196	Support wall, straight	4
46519	Holding strip 600	2
46520	Angle strip 600	2

ISO standard US ISO 318 MUS318/5 HE

Dimensions, W × H × D, mm	Quantity
356 × 870 × 451	1

Order no.	Designation	Quantity
46007	PC module 300 × 400 × 50	1
46038	PC divider 400 × 50	1
46039	PC divider 300 × 50	1
46006	PC module 300 × 400 × 100	4
46036	PC divider 400 × 100	4
46037	PC divider 300 × 100	4
46026	Safety stop system	10
46196	Support wall, straight	4
46519	Holding strip 600	2
46520	Angle strip 600	2

Standard cupboard configurations for infusions (lower cabinet).

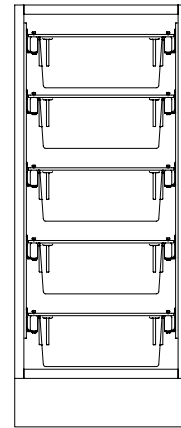
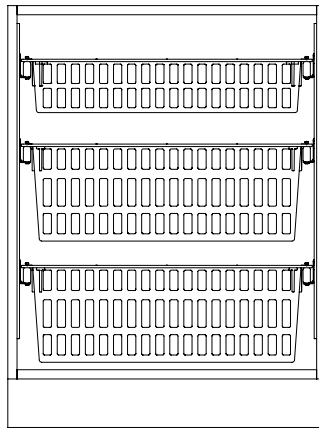
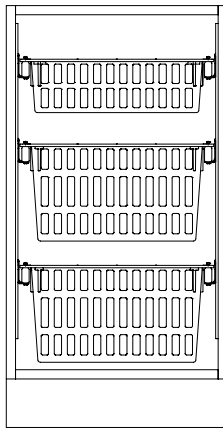

ISO standard US ISO 418 IUS418/5 HE

Dimensions, W × H × D, mm	Quantity
456 × 870 × 651	1

Order no.	Designation	Quantity
46005	ABS modular basket 600 × 400 × 100	1
46029	Divider 600 × 100	1
46030	Divider 400 × 100	2
46000	ABS modular basket 600 × 400 × 200	2
46027	Divider 600 × 200	2
46028	Divider 400 × 200	2
46022	T-piece	2
46502	Divider fixing – POM	8
46521	Notched rail 600	4
46346	Telescopic rail, hook-on, 600 mm, right	3
46347	Telescopic rail, hook-on, 600 mm, left	3

ISO standard US ISO 618 IUS618/5 HE

Dimensions, W × H × D, mm	Quantity
656 × 870 × 451	1

Order no.	Designation	Quantity
46005	ABS modular basket 600 × 400 × 100	1
46029	Divider 600 × 100	1
46030	Divider 400 × 100	2
46000	ABS modular basket 600 × 400 × 200	2
46027	Divider 600 × 200	2
46028	Divider 400 × 200	2
46022	T-piece	2
46502	Divider fixing – POM	8
46521	Notched rail 600	4
46344	Telescopic rail, hook-on, 400 mm, right	3
46345	Telescopic rail, hook-on, 400 mm, left	3

ISO standard US ISO 318 IUS318/5 HE

Dimensions, W × H × D, mm	Quantity
356 × 870 × 651	1

Order no.	Designation	Quantity
46006	PC module 300 × 400 × 100	3
46036	PC divider 400 × 100	3
46037	PC divider 300 × 100	3
46521	Notched rail 600	4
46344	Telescopic rail, hook-on, 400 mm, right	5
46345	Telescopic rail, hook-on, 400 mm, left	5

Standard cupboard configurations for wall unit.

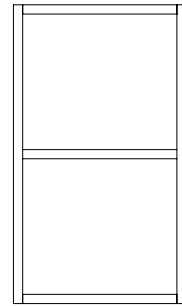
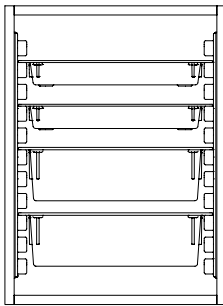

ISO standard MOS ISO 418 MOS418/4 HE

Dimensions, W × H × D, mm	Quantity
456 × 616 × 360	1

Order no.	Designation	Quantity
46007	PC module 300 × 400 × 50	2
46038	PC divider 400 × 50	2
46039	PC divider 300 × 50	2
46006	PC module 300 × 400 × 100	2
46036	PC divider 400 × 100	2
46037	PC divider 300 × 100	2
46026	Safety stop system	8
46049	Support wall for wall unit 495 × 260	2

ISO standard MOS ISO 618 MOS618/4 HE

Dimensions, W × H × D, mm	Quantity
656 × 616 × 360	1

Designation	Quantity
Shelf compartment	1

Wall units with fixed shelf compartment

ISO standard MOS ISO 318 MOS318/4 HE

Dimensions, W × H × D, mm	Quantity
356 × 616 × 360	1

Designation	Quantity
Shelf compartment	1

ZARGES shelving system

A solution with endless possibilities.

The versatile system can be effortlessly adapted to all your needs. Thanks to the modular design, all components can be combined with other ZARGES systems for even

greater efficiency and sustainability in your supply and storage logistics.





Shelving systems for hospital dispensary



Sterile storage



Kanban storage system



Secure storage



Universal shelving system with ISO standard modules

ZARGES shelving system

ZARGES storage and retrieval shelving is suitable for universal applications and can be put together and configured individually by selecting from our range of modules and modular baskets. Thanks to their open design, they are easy to clean.

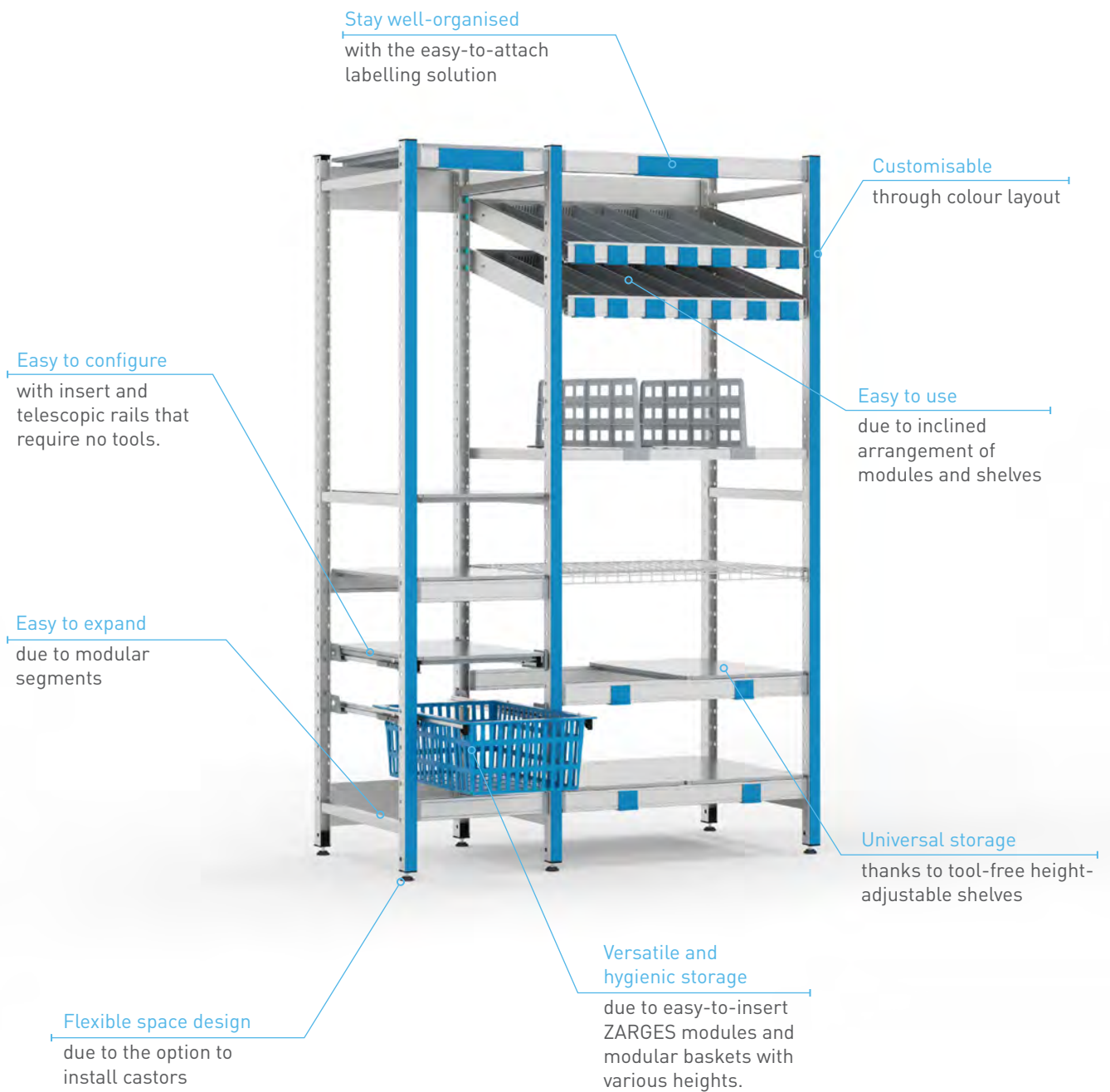

Modular design

Highly flexible thanks to modular design: The base unit can be supplemented with countless add-on units – also retrospectively.



Tool-free assembly and extension thanks to easy clip-on adapter pieces and straight connectors

Labelling



Straight connector label holder

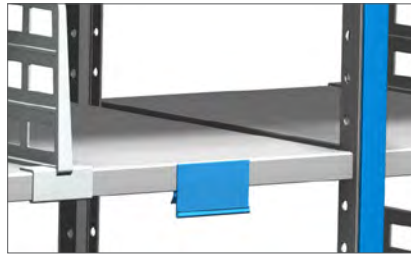

Shelf compartment label holder



Shelf segment label holder

Customisable



Customisable using coloured front panels

Standard: Blue RAL 5024

Optional: White aluminium RAL 9006, red RAL 3020
Yellow RAL 1016, Green RAL 6018



Flexibility



Optional castor set

Possible configurations

Standard shelving for ISO standard modules

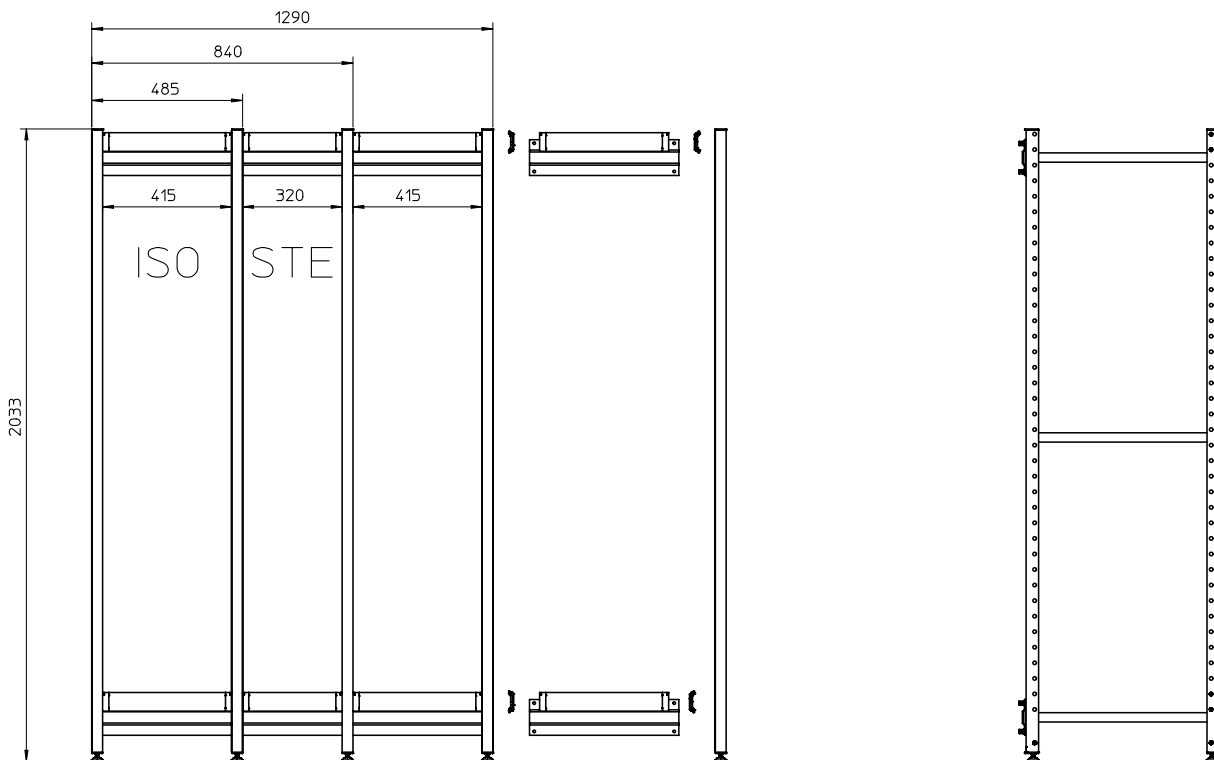

Shelving components (depth: 600 mm)

Order no.	Designation	Number of rows				For each further row added
		1	2	3	4	
31010776	Shelving segment 2000 × 600 mm aluminium in blue	2	3	4	5	1
31010795	Straight connector 415 mm	2	4	6	8	2
31010836	Straight profile, rear 415 mm	2	4	6	8	2
31011716	Set of connecting elements	1	2	3	4	1
46270	Insert rails, 600 mm (D), straight installation, anodised aluminium	-	-	-	-	-
46271	Insert rails, 620 mm (D), angled installation, anodised aluminium	-	-	-	-	-

Rails to be ordered separately.

Shelving components (depth: 400 mm)

Order no.	Designation	Number of rows				For each further row added
		1	2	3	4	
31011337	Shelving segment 2000 × 400 mm aluminium in blue	2	3	4	5	1
31011281	Straight connector 615 mm	2	4	6	8	2
31011349	Straight profile, rear 615 mm	2	4	6	8	2
31011716	Set of connecting elements	1	2	3	4	1
46272	Insert rails, 400 mm (D), straight installation, anodised aluminium	-	-	-	-	-
46273	Insert rails, 420 mm (D), angled installation, anodised aluminium	-	-	-	-	-

Rails to be ordered separately.

Shelf components sterile goods unit STE (600 mm deep)

Order no.	Designation	Number of rows				For each further row added
		1	2	3	4	
31010776	Shelving segment 2000 × 400 mm aluminium in blue	2	3	4	5	1
31011774	Straight connector 320 mm	2	4	6	8	2
31011863	Straight profile, rear 320 mm	2	4	6	8	2
31011716	Set of connecting elements	1	2	3	4	1
31011709	Insert rail can be hooked in for sterile containers	-	-	-	-	-

Insert rail can be attached and ordered separately for sterile containers.

Standard shelving accessories for ISO standard modules

Order no.	Designation
31010947	Shelf compartment ISO 400 × 600
31011697	Telescopic rails for shelf, left 600 mm
31011698	Telescopic rails for shelf, right 600 mm
31011699	Telescopic rails for shelf, left 400 mm
31011700	Telescopic rails for shelf, right 400 mm
31010945	Label holder shelf, 50 mm
31011649	Label holder shelf, 250 mm
31010949	Adapter for label holder
31011692	Castor set aluminium shelf
see from page 16	ZARGES modular system

Installation options for shelf compartment

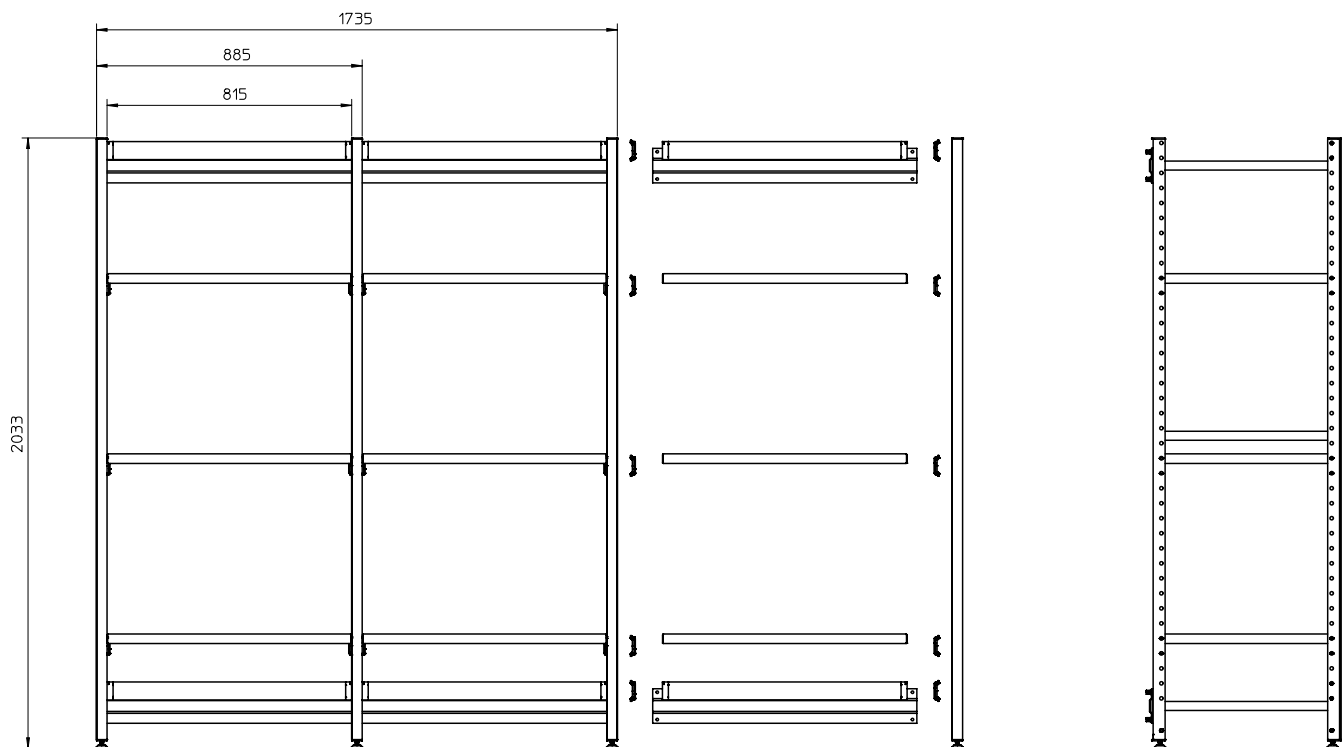

Shelving components (depth: 600 mm)

Shelf width			Designation	Number of rows				For each further row added
800 mm	1000 mm	1200 mm		1	2	3	4	
	31010776		Shelving segment 2000 × 600 mm aluminium in blue	2	3	4	5	1
31010801	31011657	31011254	Straight connector	2	4	6	8	2
31010837	31011658	31011660	Straight profile rear	2	4	6	8	2
	31011716		Set of connecting elements	1	2	3	4	1
2 × 31010947	-	3 × 31010947	Shelf compartment ISO 400 × 600	-	-	-	-	-
31011673	31011674	31011675	Anodised aluminium shelf compartment	-	-	-	-	-
31010542	31011676	31011677	Stainless steel shelf compartment	-	-	-	-	-
31010896	31011687	31011688	Wire mesh shelf compartment	-	-	-	-	-

Order shelf compartment separately as required.

Shelving components (depth: 400 mm)

Shelf compartment width			Designation	Number of rows				For each further row added
800 mm	1000 mm	1200 mm		1	2	3	4	
	31011337		Shelving segment 2000 × 400 mm aluminium in blue	2	3	4	5	1
31010801	31011657	31011254	Straight connector	2	4	6	8	2
31010837	31011658	31011660	Straight profile rear	2	4	6	8	2
	31011716		Set of connecting elements	1	2	3	4	1
-	-	2 × 31010947	Shelf compartment ISO 600 × 400	-	-	-	-	-
31011678	31011679	31011680	Anodised aluminium shelf compartment	-	-	-	-	-
31011681	31011682	31011683	Stainless steel shelf compartment	-	-	-	-	-
31011689	31011690	31011691	Wire mesh shelf compartment	-	-	-	-	-

Order shelf compartment separately as required.

Accessories for shelf with shelf compartment

Order no.	Designation	Order no.	Designation
31011041	Shelf compartment divider, plastic 600	31010945	Label holder shelf, 50 mm
31011778	Wire mesh compartment divider, 600	31011649	Label holder shelf, 200 mm
31011779	Wire mesh compartment divider, 400	31011693	Label holder for shelf compartment, 50 mm
31011766	Wire mesh compartment label holder	31011695	Label holder for shelf compartment, 200 mm
31011692	Castor set aluminium shelf	31010949	Adapter for label holder

ZARGES shelving system: Accessories

A wide range of accessories are available for the ZARGES shelving systems, such as insert rails, label holders and shelves (including options with wire mesh). Everything you need for your day-to-day work.



**1 Straight insert rails**

- ▶ Plastic, glass fibre reinforced

2 Insert rails with incline

- ▶ Anodised aluminium

3 Medication shelf compartments, 800 mm

- ▶ Optimum medication storage with subdivision and ergonomic angled drawer.

4 Open shelf with wire mesh compartment**5 Shelf compartment divider**

- ▶ In plastic and chrome-plated steel

6 Shelf label holder, 250 mm

- ▶ Suitable for straight connectors, can be clipped-on without tools

7 Insert rail can be hooked in for STE

- ▶ Can be adjusted without the use of tools

8 Adapter for label holder 46551

- ▶ Clip-on and height adjustable.

9 Castor set (optional)**10 Shelf label holder, 50 mm**

- ▶ Suitable for straight connectors, can be clipped on without tools.

11 Shelf compartment

- ▶ ISO shelf compartment 400 x 600 in plastic
- ▶ Wire mesh compartment in stainless steel, open
- ▶ Anodised aluminium, closed
- ▶ Stainless steel, closed

12 ZARGES modular system

- ▶ See from page 16

13 Telescopic rails, hook-in with soft closing

- ▶ Can be adjusted without the use of tools.

ZARGES shelving system: Areas of application

The universal shelving system for wards, operating theatres, outpatient clinics, central storage facilities and hospital dispensaries.



Universal shelf system with ISO norm modules

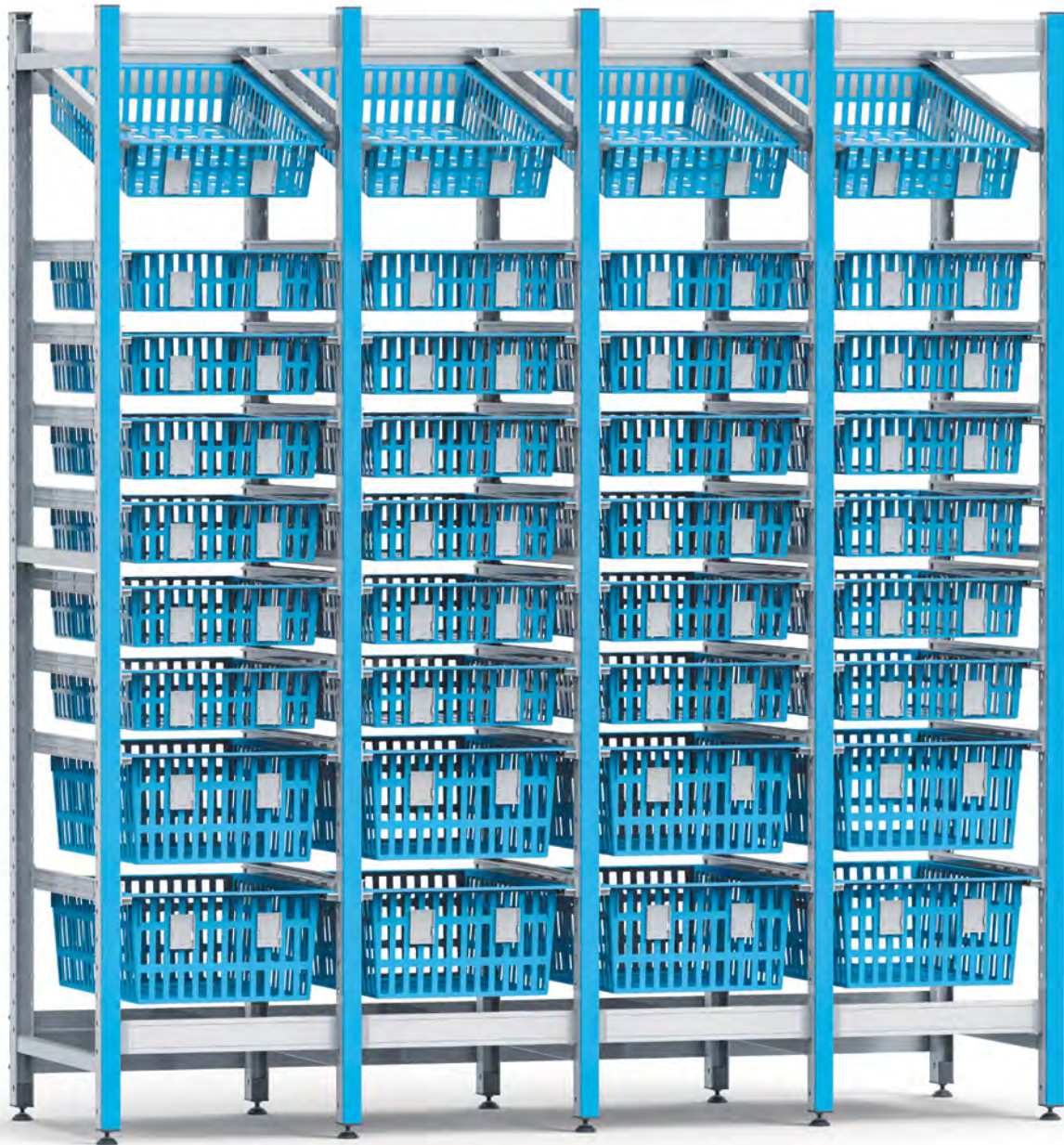

The ideal solution for storing all the products needed for efficient patient care. The front sides are colour customisable to enable quick identification of different product groups and departments.

Hospital dispensary storage system

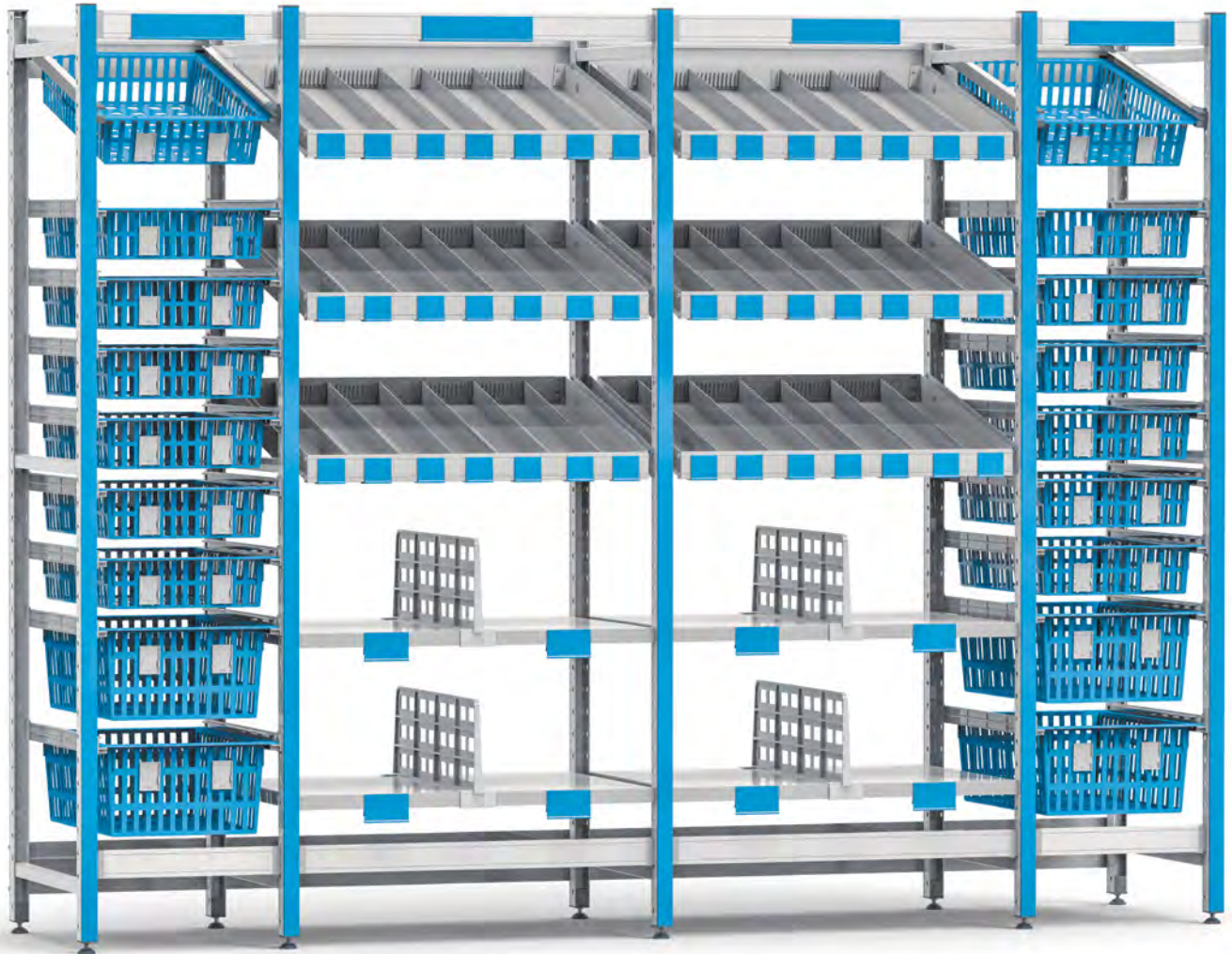

The ZARGES shelving system for hospital dispensaries helps to achieve the neat and tidy storage of pharmacy goods. Clear and easy to access to all medicines at all times. For fast and secure retrieval when preparing patient-specific medication.

System storage for sterile goods



Variable use of individually extendible and height-adjustable storage levels and dividable shelves allow both sterile containers and flexible packs to be clearly organised and easily removed. All components are easily height-adjustable without tools – for maximum flexibility at any height.

Kanban storage system

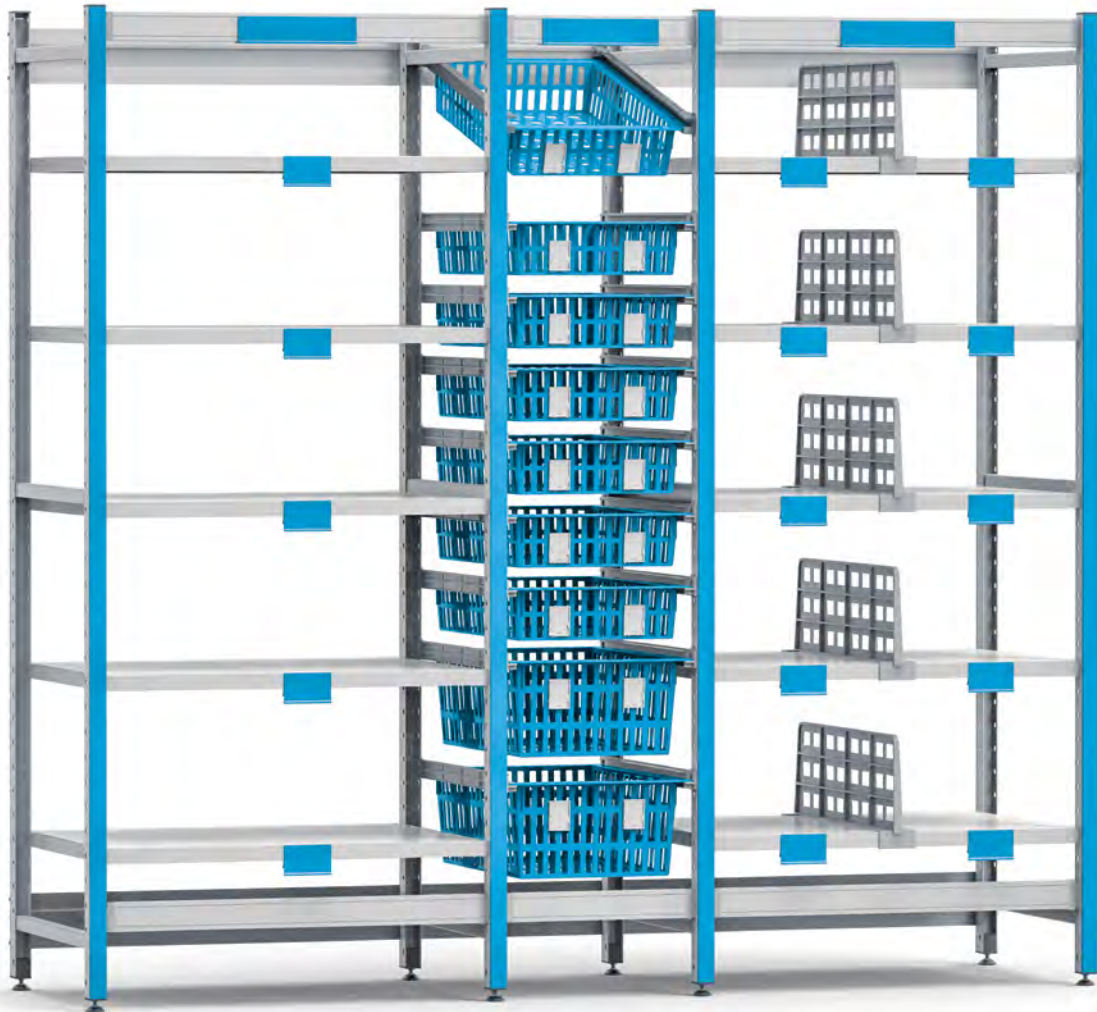

The ZARGES shelving system supports stocking and Kanban-based ordering processes for different packaging units – safely and efficiently. All patient care products are clearly stored and easy to access. Re-ordering is easy and can be done at a glance.

Individual shelving solutions

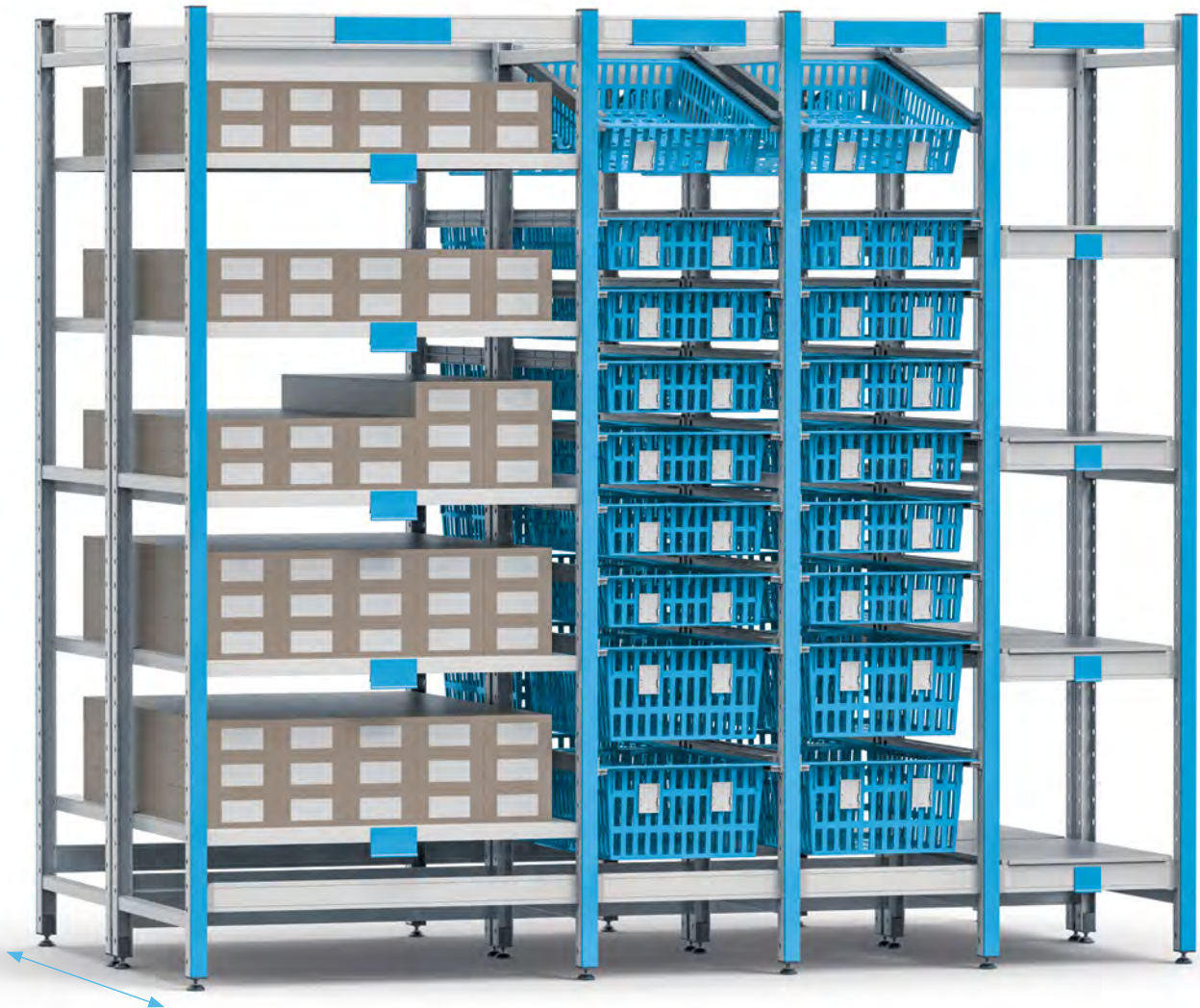

Shelf compartment depth:
800 mm or 1200 mm

Order the way you want. The ZARGES storage shelving system can be individually combined. Every stored item is clearly stored, easy to access and re-order, whether for individual packs, large packs or entire packaging units such as cardiac catheters as consignment stock. For smooth workflows.

The universal shelving system for ISO standard modules.

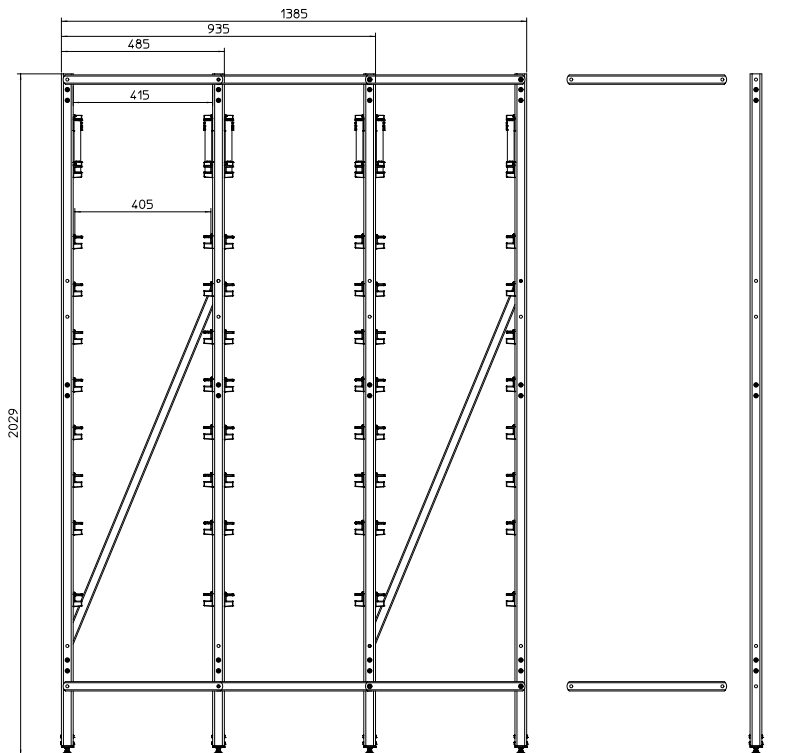

Shelving components (depth: 600 mm)

Order No. Steel shelving	Designation	Number of rows				For each further row added
		1	2	3	4	
46140	Shelving segment, 2,000 × 600 mm (H × D)	2	3	4	5	1
46560	Connecting rod, 479 mm (L)	2	4	6	8	2
46562	Connecting rod, diagonal, 1,206 mm (L)	2	4	6	8	2
46280	Set of connecting elements	1	2	3	4	1
46270	Insert rail, 600 mm (D), straight installation, plastic	-	-	-	-	-
46271	Insert rail, 620 mm (D), installation with incline, anodised aluminium	-	-	-	-	-

Insert rails to be ordered separately

Shelving components (depth: 400 mm)

Order No. Steel shelving	Designation	Number of rows				For each further row added
		1	2	3	4	
46141	Shelving segment, 2,000 × 400 mm (H × D)	2	3	4	5	1
46561	Connecting rod, 679 mm (L)	2	4	6	8	2
46562	Connecting rod, diagonal, 1,206 mm (L)	2	4	6	8	2
46563	Set of connecting elements	1	2	3	4	1
46272	Insert rail, 400 mm (D), straight installation, anodised aluminium	-	-	-	-	-
46273	Insert rail, 420 mm (D), installation with incline, anodised aluminium	-	-	-	-	-

Insert rails to be ordered separately

Configuration options for shelving with shelf compartment.

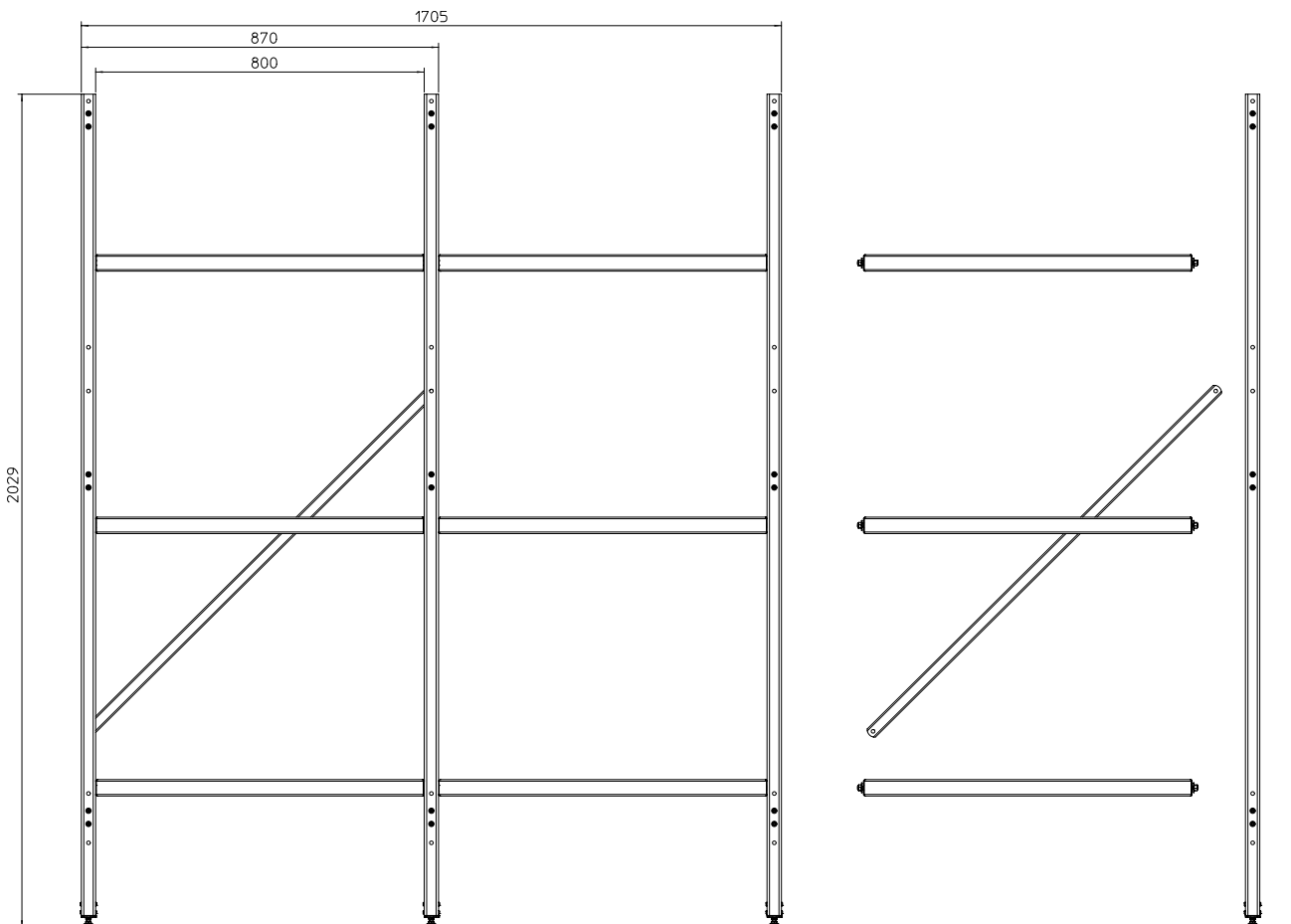

Shelving components (depth: 600 mm)

Order No. Steel shelving	Designation	Number of rows				For each further row added
		1	2	3	4	
46140	Shelving segment, 2,000 × 600 mm (H × D)	2	3	4	5	1
46072	Shelf compartment, 800 × 600 mm (L × D)	-	-	-	-	-
46562	Connecting rod, diagonal, 1,206 mm (L)	1	1	2	2	1
46280	Set of connecting elements	2	3	4	5	1

Shelving components (depth: 400 mm)

Order No. Steel shelving	Designation	Number of rows				For each further row added
		1	2	3	4	
46141	Shelving segment, 2,000 × 400 mm (H × D)	2	3	4	5	1
46079	Shelf compartment, 800 × 400 mm (L × D)	-	-	-	-	-
46562	Connecting rod, diagonal, 1,206 mm (L)	1	1	2	2	1
46280	Set of connecting elements	2	3	4	5	1

ZARGES storage and retrieval trolleys.

Wherever you need to store or transport laundry, medication, expendable and durable goods safely and hygienically, the storage and retrieval trolley is the perfect solution.

This multifunctional trolley is used in clinics, laundries, industry, the catering trade and public authorities.



ZARGES storage and retrieval trolley

Wherever you need to store or transport laundry, medication, expendable and durable goods safely and hygienically, the storage and retrieval trolley is the perfect solution.

This multifunctional trolley is used in clinics, laundries, industry, the catering trade and public authorities.

Easy to use

due to the ability to mount insert rails and modules at a variety of angles and configurations.

Stay well-organised

with the easy-to-attach labelling solution

Versatile and hygienic storage

from to easy-to-insert ZARGES modules and modular baskets with various heights

Customisable

through colour layout

Easy to configure

with insert and telescopic rails that require no tools.

Flexible space design

due to the option to install castors

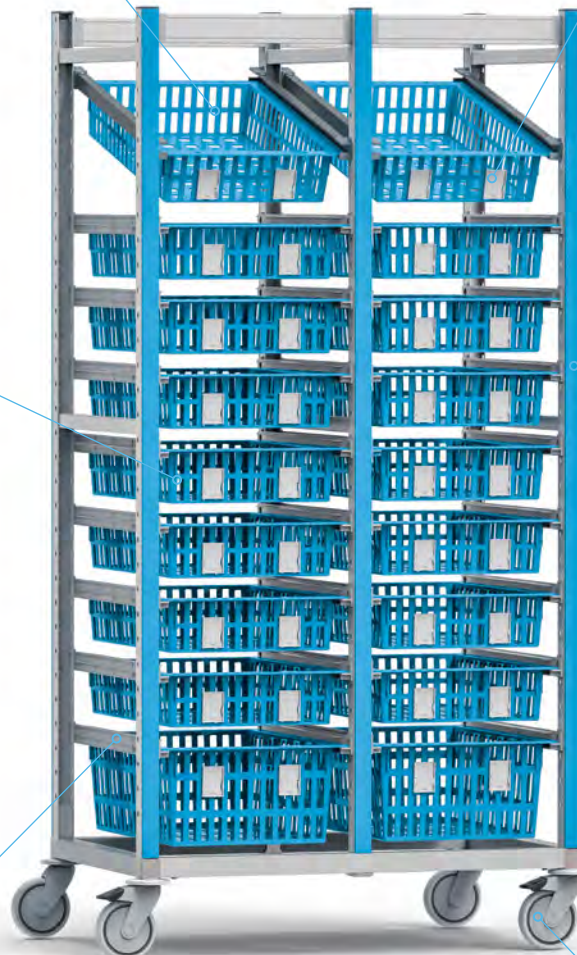

Large or small, they are always the right choice:
Storage and retrieval trolleys.

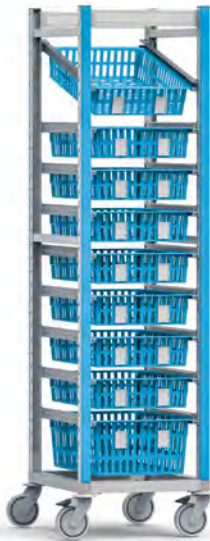

Single-column storage and retrieval trolley

Order no.	Material	Slide-in unit width, mm	Dimensions, L x D, mm	Height, mm
31011246	Anodised aluminium	400	540 x 682	1910
31011278	Anodised aluminium	600	740 x 482	1910
366035	Powdered steel	400	544 x 675	1900
367568	Powdered steel	600	744 x 475	1900

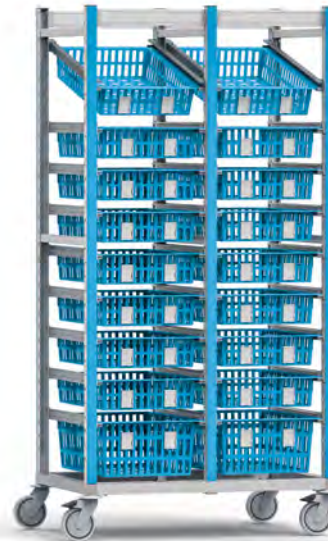

Double-column storage and retrieval trolley

Order no.	Material	Slide-in unit width, mm	Dimensions, L x D, mm	Height, mm
31011003	Anodised aluminium	400	990 x 682	1910
31011288	Anodised aluminium	600	1390 x 482	1910
366045	Powdered steel	400	993 x 675	1900
367567	Powdered steel	600	1393 x 475	1900

Triple-column storage and retrieval trolley

Order no.	Material	Slide-in unit width, mm	Dimensions, L x D, mm	Height, mm
31011701	Anodised aluminium	400	1140 x 682	1910
366043	Powdered steel	400	1440 x 675	1900



Accessories

Order no.	Material
46059	Insert rail, 600 mm (D), straight installation
46271	Insert rail, 620 mm (D), installation with incline
46054	Insert rail, 400 mm (D), straight installation
46273	Insert rail, 420 mm (D), installation with incline
31010542	Shelf compartment 800 x 600 mm (L x D)
31011697	Telescopic drawer for shelf, left 600 mm
31011698	Telescopic drawer for shelf, right 600 mm
31011699	Telescopic drawer for shelf, left 400 mm
31011700	Telescopic drawer for shelf, right 400 mm

Storage and retrieval trolley with shelf compartment

Order no.	Material	Slide-in unit width, mm	Dimensions, L x D, mm	Height, mm
31011247	Anodised aluminium	400	1390 x 682	1910

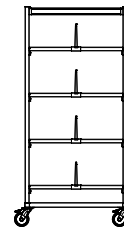
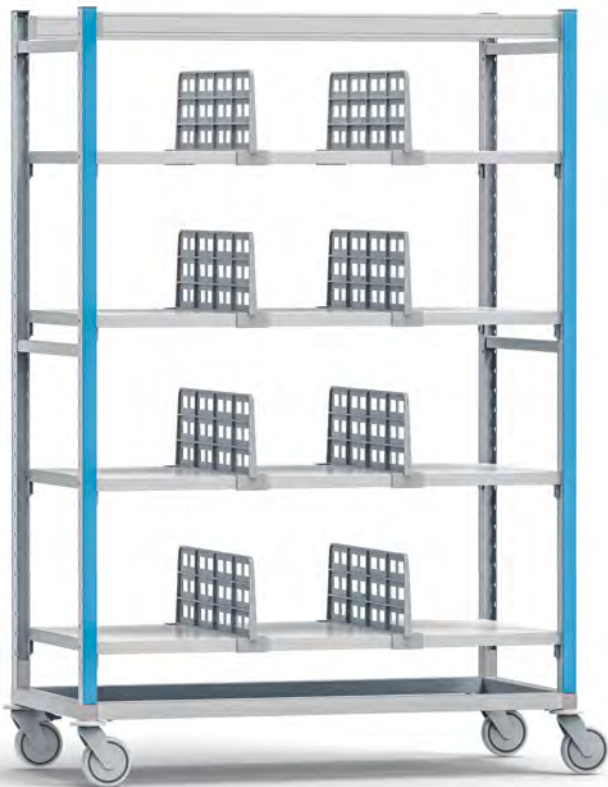

Sorting trolley 800

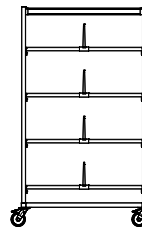

Sorting trolley 1000

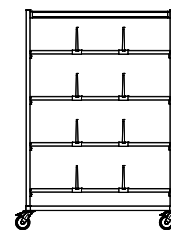

Sorting trolley 1200

Sorting trolley 600 deep

Order no.	Slide-in unit width	Shelf compartment	Dimensions, L × W × H, mm
31011741	800	ISO 400 × 600 modular	990 × 682 × 1910
31011702	800	Anodised aluminium	990 × 682 × 1910
31011705	800	Wire mesh compartment	990 × 682 × 1910
31011757	800	Stainless steel	990 × 682 × 1910
31011704	1000	Anodised aluminium	1190 × 682 × 1910
31011706	1000	Wire mesh shelf compartment	1190 × 682 × 1910
31011758	1000	Stainless steel	1190 × 682 × 1910
31011742	1200	ISO 400 × 600 modular	1390 × 682 × 1910
31011255	1200	Anodised aluminium	1390 × 682 × 1910
31011707	1200	Wire mesh compartment	1390 × 682 × 1910
31011759	1200	Stainless steel	1390 × 682 × 1910

Sorting trolley 400 deep

Order no.	Shelf compartment width	Shelf compartment width	Dimensions, L × W × H, mm
31011743	800	ISO 600 × 400 modular	990 × 482 × 1910
31011745	800	Anodised aluminium	990 × 482 × 910
31011760	800	Stainless steel	990 × 482 × 1910
31011746	1000	Anodised aluminium	1190 × 482 × 1910
31011761	1000	Stainless steel	1190 × 482 × 1910
31011744	1200	ISO 400 × 600 modular	1390 × 482 × 1910
31011747	1200	Anodised aluminium	1390 × 482 × 1910
31011762	1200	Stainless steel	1390 × 482 × 1910

Sorting trolley accessories

Order no.	Slide-in unit width
31010947	Shelf compartment ISO 400 × 600
31011673	Aluminium shelf compartment 800 × 600
31011674	Aluminium shelf compartment 1000 × 600
31011675	Aluminium shelf compartment 1200 × 600
31010542	Stainless steel shelf compartment 800 × 600
31011676	Stainless steel shelf compartment 1000 × 600
31011677	Stainless steel shelf compartment 1200 × 600
31010896	Wire mesh shelf compartment 800 × 600
31011687	Wire mesh shelf compartment 1000 × 600
31011688	Wire mesh shelf compartment 1200 × 600
31011678	Aluminium shelf compartment 800 × 400
31011679	Aluminium shelf compartment 1000 × 400
31011680	Aluminium shelf compartment 1200 × 400
31011681	Stainless steel shelf compartment 800 × 400
31011682	Stainless steel shelf compartment 1000 × 400
31011683	Stainless steel shelf compartment 1200 × 400
31010818	Shelf segment adapter
31011041	Shelf compartment divider, plastic
31011778	Wire mesh compartment divider 600 mm
31010945	Label holder for straight connector 50 mm
31011649	Label holder for straight connector 250 mm
31011693	Label holder for shelf compartment, 50 mm
31011695	Label holder for shelf compartment, 250 mm
31010949	Adapter for label holder
31011766	Label holder for wire mesh compartment

Well stocked in every situation: MPO storage trolleys.

It is important to ensure you have the right amount of the required supplies in the right place and at the right time. The MPO storage trolley is able to help you achieve just that. It meets hygiene requirements and is easy to clean because

its rolling tambour doors and all its fittings can be removed individually and without the use of tools. The materials used (aluminium, plastic and ABS) guarantee sturdiness and a long service life.



The MPO storage trolley in detail.



1 Corner profiles. Ergonomically shaped, anodised aluminium profile sections. **2 Front panel.** Anodised aluminium, can be fitted without tools, can be supplied with cylinder, combination or card lock. **3 Interior fittings.** Modular drawers, modular baskets and shelf compartments can be installed as required on plastic support walls and telescopic rails. **4 Trolley base.** Made from sturdy PPH plastic panel without undercut, easy to clean. **5 Side walls and rear wall.** Made of plastic-coated aluminium, white, available in other colours. **6 Chassis.** 4 twin-wheel swivel castors with $\varnothing 125$ mm, 2 of which with wheel brakes. **7 Rolling tambour door.** Space-saving plastic rolling tambour door that can be removed for cleaning without the use of tools.

Well-equipped for every situation: rolling tambour door.



1 ISO
Module width 600 mm



1 ISO
Module width 400 mm





















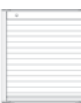



2 ISO
Module width 2 x 600 mm



2 ISO
Module width 2 x 400 mm

Everything you need: available in various sizes.

Heights	ISO widths			
	1 ISO		2 ISO	
	400 mm deep	600 mm deep	400 mm deep	600 mm deep
750 mm				
Order no.	46523	46524	–	–
Outside dimensions, L × W × H, approx. mm	685 × 556 × 750	485 × 756 × 750	–	–
Weight, approx. kg	31.5	33.0	–	–
900 mm				
Order no.	46530	46531	46532	46533
Outside dimensions, L × W × H, approx. mm	685 × 556 × 900	485 × 756 × 900	1,345 × 556 × 900	945 × 756 × 900
Weight, approx. kg	33.0	34.5	58.5	61.0
1,000 mm				
Order no.	46534	46535	46536	46537
Outside dimensions, L × W × H, approx. mm	685 × 556 × 1,000	485 × 756 × 1,000	1,345 × 556 × 1,000	945 × 756 × 1,000
Weight, approx. kg	34.5	35.0	62.5	62.5
1,100 mm				
Order no.	46538	46539	46540	46541
Outside dimensions, L × W × H, approx. mm	685 × 556 × 1,100	485 × 756 × 1,100	1,345 × 556 × 1,100	945 × 756 × 1,100
Weight, approx. kg	36.5	36.0	65.5	62.5
1,500 mm				
Order no.	46542	46543	46544	46545
Outside dimensions, L × W × H, approx. mm	685 × 556 × 1,500	485 × 756 × 1,500	1,345 × 556 × 1,500	945 × 756 × 1,500
Weight, approx. kg	42.5	46.5	75.0	79.5
1,800 mm				
Order no.	46546	46547	46548	46549
Outside dimensions, L × W × H, approx. mm	685 × 556 × 1,800	485 × 756 × 1,800	1,345 × 556 × 1,800	945 × 756 × 1,800
Weight, approx. kg	48.5	53.5	85.5	91.0

G = Glass door

MPO with glass door. Keeps items in sight and readily accessible.



Stability

Thanks to the all-round aluminium frame.



Secure storage

With optional lock systems.



Sturdy and functional

Due to flat hinges that are adjustable in three directions.

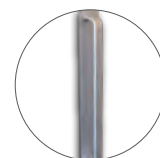

Comfort

Due to ergonomic handle made of anodised aluminium. Door opens up to approx. 170 degrees.



Items are kept perfectly in sight

Thanks to tempered safety glass.



Mobile storage

- Modular support walls provide maximum flexibility.
- The colours of the side and rear walls are customisable.



Optimum mobility

Due to four plastic twin-wheel castors, two of which equipped with brakes; corner bumpers available as an option.

- ▶ Door frame made of sturdy aluminium profiles.
- ▶ Tempered safety glass compliant with DIN EN 12150 for high resistance to shock and impact.
- ▶ Door opens up to approx. 170 degrees.
- ▶ Door is fitted with versatile flat hinges allowing adjustment in 3 directions.

Configurable trolley interior

- ▶ ABS support walls with or without tilting function.
- ▶ Telescopic rails that can be fitted as required.
- ▶ Telescopic rails for fixed installation.

And most crucially: It's a tried-and-tested solution.



Vertical trolley handle



Bumper

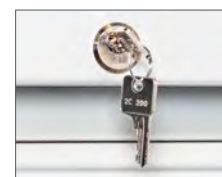

Locking systems can be fitted with a cylinder, digital or card lock.

Your options.



1 ISO

Module width
600 mm



1 ISO

Module width
400 mm



2 ISO

Module width
2 x 600 mm



2 ISO

Module width
2 x 400 mm



Select one of the standard colours.



RAL 9016,
Traffic white



RAL 140 60 50,
Green



RAL 095 80 80,
Yellow



RAL 240 70 30,
Blue



RAL 030 40 60,
Red

Modular support elements provide maximum flexibility.



MPO storage trolley – standard model

- ▶ Plastic support walls throughout.
- ▶ Suitable for ZARGES ISO modules and modular drawers.



MPO storage trolley – combination model

- ▶ Can be combined with plastic support wall and hook-on telescopic rails.
- ▶ Suitable for ZARGES ISO modules, modular drawers, pull-out shelf compartment.

Versatile enough for any task: interior fittings.



Modular drawers



Modular baskets



Shelf compartments



Special solutions, catheter drawer

Order no.	Designation
31003573	Shelf compartment 400 × 600, anodised aluminium, flat
31003669	Shelf compartment 600 × 400, anodised aluminium, flat
31003644	Shelf compartment 400 × 600, anodised aluminium, high
31003677	Shelf compartment 600 × 400, anodised aluminium, high

Accessories, MPO storage trolleys.

Locking systems



Cylinder lock



Digital lock



Card lock

Front panel and lock	Dimensions, W, mm	Order no.
Panel without lock	600	31001572
Panel without lock	400	31001575
Panel with cylinder lock	600	31001842
Panel with cylinder lock	400	31001847
Panel with digital locks	600	31001887
Panel with digital locks	400	31001886
Panel with card locks	600	31001888
Panel with card locks	400	31001889



Bumpers

Designation	Order no.
Bumper set	31002033



Handle

Designation	Dimensions, mm	Order no.
Anodised aluminium ergonomic handle, for 600 depth	600	46459
Anodised aluminium ergonomic handle, for 400 depth	400	46460
Cast aluminium ergonomic handle, plastic coated	400	31000752



Side worktop

Designation	Dimensions, mm	Order no.
Folding worktop, ABS	400 deep	46154
Folding worktop HPL	400 deep	46489

Rolling tambour door

Height, mm	Width 400 mm, Order No.	Width 600 mm, Order No.
750	31001870	31001869
900	31001872	31001871
1,000	31001873	31001261
1,100	31001875	31001874
1,500	31001868	31001876
1,800	31001278	31001410



Colour, MPO storage trolleys

Optional models – Individuality is our strong point.

Side wall variants

- ▶ Standard colour for side wall is white.
- ▶ 4 further colours available as options.
- ▶ Individual corporate design on request.



Select one of the standard colours.



RAL 9016,
Traffic white



RAL 140 60 50,
Green



RAL 095 80 80,
Yellow



RAL 240 70 30,
Blue



RAL 030 40 60,
Red



Storage made to measure

For expendables
or pharmacy goods



Mobile storage cabinets

For ward supplies



Storage for workspace

Catheter or surgery case trolley



Mobile workstations

Storage space directly where you work

Ordering and planning has never been easier with the ZARGES Medical Configurator



Design your MPO transportation and storage trolley according to your requirements using the ZARGES Medical Configurator.

Excellent 360° visualisation enables quick and simple in-house agreement on a configured product.

A drawing and quote for the configuration will then be instantly issued.

Configure your products now:
medical.zarges.com

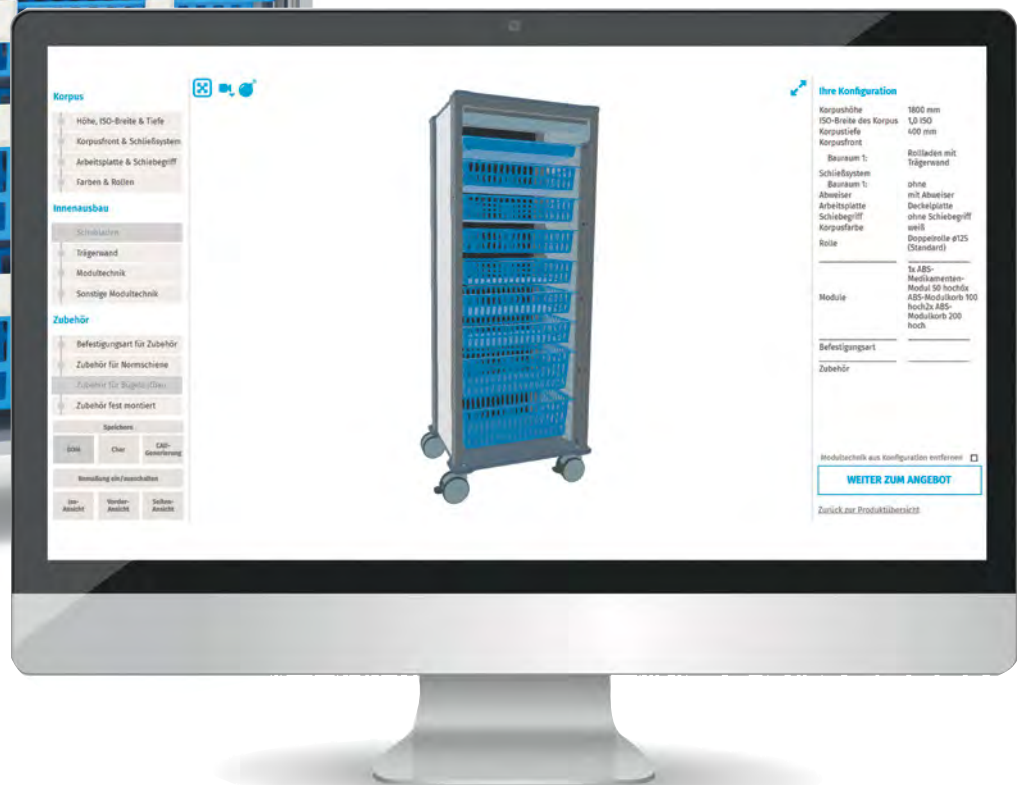



Medical

Mobile organisation systems

Products to support ward-internal processes and mobile storage in nursing, medication distribution, during ward rounds and in services.

.....

Product overview	84–85
MPO transportation trolley	86–91
MPO nursing trolleys	92–93
MPO medication trolleys	94–95
MPO anaesthesia trolleys	96–97
MPO emergency trolleys	98–99
MPO Dressings trolleys	100–101
MPO IT trolleys	102–103
Accessories for MPO transportation trolleys	104–108
MPO configurator	109
Locking systems	110–111
Multi-function trolley	112–113
Medication distribution systems	114–116
Medication cassettes	117
Pharmacy shelving	118
Accessories	119



MPO dressing trolley



Distributing medication



MPO anaesthesia trolley



Nursing trolley with drawers



Medication trolley with rolling tambour door



Nursing trolley with removable modular baskets

A systematic range for an optimum solution.

In the healthcare sector, nursing trolleys, dressing trolleys and medication trolleys have to fulfil a wide range of requirements. ZARGES modular nursing and organisation trolleys can be perfectly tailored for any applications based on your specific requirements. A modular system comprising just a few basic components allows a wide variety

of options which you can configure to your specific needs and requirements as regards both design and functionality. And thanks to their unlimited mobility, all MPO models can be deployed very flexibly – as nursing trolleys, medication trolleys or mobile computer workstations.



1 Worktop options. ABS plastic with or without raised edges, or flat HPL plastic. **2 Ergonomic handle.** Plastic-coated cast aluminium for comfortable handling, easy to clean. **3 Side wall.** Available with coloured centre segment. **4 Fender.** Abrasion- and disinfectant-resistant plastic padding. **5 Castors.** 4 precision twin-wheel swivel castors, \varnothing 125 mm, for maximum mobility in confined spaces, 2 of which with brakes; bumper available as an option. **6 Corner profiles.** Made of anodised aluminium. **7 Trolley base.** Made of sturdy plastic panel. **8 Drawer handle.** Plastic-coated cast aluminium for convenient handling, easy to clean with optional colour coding.

Standard models.



Drawers

Suitable for ZARGES ISO modules, mounted on telescopic rails.



Rolling tambour doors with support wall

Suitable for ZARGES ISO modules and modular drawers, mounted on plastic support wall, space-saving opening.



Rolling tambour doors with variable telescopic rails

Suitable for ZARGES ISO modules and modular drawers, mounted on telescopic soft-close rails.



Open, with modular drawers

Mounted on telescopic rails and removable.

Standard sizes.

Working heights



Working height approx. 900 mm = 58 HE



Working height approx. 1,000 mm = 66 HE



Working height approx. 1,100 mm = 74 HE

1 HE = 12.5 mm, the usable height is given in HE.

ISO widths



0.5 ISO

- ▶ Slide-in width for ISO half modules: 400 × 300 mm.
- ▶ Dimensions: (W × D) approx. 520 × 595 mm.



1 ISO

- ▶ Slide-in width for ISO modules: 600 × 400 mm.
- ▶ Dimensions: (W × D) approx. 720 × 595 mm.



2 ISO

- ▶ Slide-in width for ISO modules: 600 × 400 mm.
- ▶ Dimensions: (W × D) approx. 1,345 × 595 mm.

Drawer arrangement and rolling tambour door.



MPO standard drawers

	Drawer height	Fits ISO modules
8 HE	100 mm	ISO module 600 × 400 × 50 mm
10 HE	125 mm	ISO module 600 × 400 × 50 mm ISO module 600 × 400 × 100 mm
12 HE	150 mm	ISO module 600 × 400 × 100 mm
20 HE	250 mm	ISO module 600 × 400 × 200 mm
26 HE	325 mm	ISO module 600 × 400 × 200 mm Suspension files

Drawers available in 0.5 und 1 ISO.

1 HE corresponds to 12.5 mm

8 HE keyboard drawer available for 0.5 and 1 ISO



MPO standard rolling tambour doors

Height, mm	Width 400 mm, Order No.	Width 600 mm, Order No.
900	31001872	31001871
1,000	31001873	31001261
1,100	31001875	31001874

Options – Individuality is our strong point.

In addition to a wide range of tried-and-tested standard models, all nursing and organisation trolleys can be configured to suit your everyday needs. The options include everything from the choice between drawer fronts and rolling tambour doors right through to support systems for slide-in units.

The support systems can be adapted to your specific requirements, and the worktops are available with various combinations of material and functions. We will be happy to help you find the right solution.

Worktops

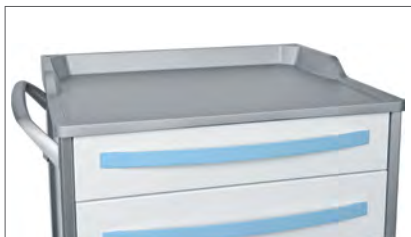

Plastic ABS with raised edges

- ▶ Removable without tools.
- ▶ Available only for 1 ISO.



ABS plastic without raised edges

- ▶ Removable without tools.
- ▶ Available only for 1 ISO.



HPL plastic without raised edges

- ▶ Fixed.
- ▶ Available for 1.2 and 0.5 ISO.

Locking systems



Cylinder lock

- ▶ Keyed alike.
- ▶ Available for drawers and rolling tambour doors.
- ▶ Optionally keyed-different.



Digital lock

- ▶ Changeable digital code.
- ▶ Available for rolling tambour doors.



Card lock

- ▶ Available for drawers and rolling tambour doors.
- ▶ Individually programmable.

Colour options, MPO transportation trolley.

Individualised colour design using coloured drawer handles



Standard colours: front panels and side panels in white, drawer handles in white aluminium.



RAL 9006,
White aluminium

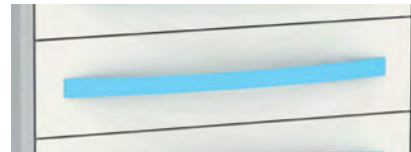

RAL 240 70 30,
Blue

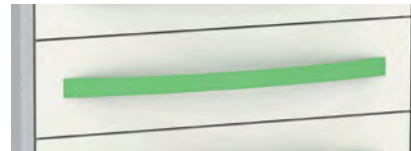

RAL 140 60 50,
Green



RAL 095 80 80,
Yellow



RAL 030 40 60,
Red

Optional colour scheme using additional coloured side walls



RAL 9016,
Traffic white



RAL 240 70 30,
Blue



RAL 140 60 50,
Green



RAL 095 80 80,
Yellow



RAL 030 40 60,
Red

Professional helpers: MPO nursing trolleys for all tasks on the wards.

This reliable helper accompanies you every step of your working day and offers clear storage of all expendable and durable goods. All accessory parts can be removed separately and are easy to clean.





MPO nursing trolley with drawers Type 1

- ▶ Equipped with drawers to accommodate modules and modular baskets in heights of 50/100/200 mm.
- ▶ Drawers mounted on telescopic rails with soft closing.
- ▶ Optionally with drawer stop.



MPO nursing trolley with rolling tambour door Type 2

- ▶ Space-saving opening through rolling tambour door, easy access.
- ▶ Interior fittings: variable loading with ZARGES modules on support walls or telescopic rails.



MPO nursing trolley Type 3

- ▶ Equipped with modular drawers.
- ▶ Modular drawers mounted on support wall.
- ▶ Front side open.



MPO nursing trolley Type 4

- ▶ Equipped with module drawers and medication modules
- ▶ Drawers and modules mounted on support wall.
- ▶ Space-saving opening with roller door, lockable with digital lock.

Available in all variants

- ▶ Standard colour: White aluminium, customised colour scheme with coloured drawer handles and central element on the side and rear wall.
- ▶ Available in various heights.
- ▶ Accessories can be freely selected from the accessories list starting on page 104.

Perfectly dosed function and design: MPO medication trolleys.

Thanks to its variable and practical interior fittings, the medication trolley allows reliable transport and patient-specific distribution of daily medication.





MPO medication trolley Type 1

- ▶ MPO transportation trolley for medication tray.
- ▶ Variable loading with ZARGES modules and medication tray on support walls.
- ▶ Rolling tambour door, lockable with digital lock.
- ▶ Height-adjustable pivot arm for laptop.
- ▶ Fold-down worktop on the side.



MPO medication trolley Type 2

- ▶ Variable loading with ZARGES modules.
- ▶ Rolling tambour door, lockable with digital lock.
- ▶ Swivel arm for laptop, height-adjustable.
- ▶ Folding worktop on the side.



MPO medication trolley Type 3

- ▶ Equipped with drawers for holding modules and modular baskets in heights of 50/100/200 mm and matching ZIP boxes.
- ▶ Drawers mounted on telescopic rails with soft closing.
- ▶ Optionally with drawer stop.



MPO medication trolley Type 4

- ▶ Equipped with a lockable drawer.
- ▶ Variable loading with ZARGES modules.
- ▶ ZARGES modules mounted on support wall.

Available in all variants

- ▶ Standard colour: White aluminium, customised colour scheme with coloured drawer handles and central element on the side and rear wall.
- ▶ Available in various heights.
- ▶ Accessories can be freely selected from the accessories list starting on page 104.

Everything in sight, everything to hand: MPO anaesthesia trolleys.

It is absolutely essential to have all the equipment you need within easy reach when administering anaesthetics. The flexible interior fittings of the MPO anaesthesia trolley ensure clearly arranged and space-saving storage.





MPO anaesthesia trolley Type 1

- ▶ Equipped with modular drawers.
- ▶ Modular drawers mounted on support wall.
- ▶ Front side open.



MPO anaesthesia trolley Type 2

- ▶ Equipped with drawers to accommodate modules and modular baskets in heights of 50/100/200 mm.
- ▶ Drawers mounted on telescopic rails with soft closing.
- ▶ Optionally with drawer stop.



MPO anaesthesia trolley Type 3

- ▶ Equipped with drawers to accommodate modules and modular baskets in heights of 50/100/200 mm.
- ▶ Drawers mounted on telescopic rails with soft closing.

Available in all variants

- ▶ Standard colour: White aluminium, customised colour scheme with coloured drawer handles and central element on the side and rear wall.
- ▶ Available in various heights.
- ▶ Accessories can be freely selected from the accessories list starting on page 104.

When there's no time to be lost: MPO emergency trolleys.

With its variable interior fittings and clearly arranged and space-saving attachment of all the components you need in an emergency, this trolley meets all requirements.





MPO emergency trolley Type 1

- ▶ Equipped with drawers to accommodate ISO standard modules, can also be adapted for modules and modular baskets in heights of 50/100/200 mm .
- ▶ Drawers mounted on telescopic rails with soft closing.
- ▶ Pivot arm for defibrillators, height-adjustable.
- ▶ Standard colour: White aluminium, colour scheme using coloured drawer handles in red RAL 030 40 60.
- ▶ Available in various heights.
- ▶ Accessories can be freely selected from the accessories list starting on page 104.



MPO emergency trolley Type 2

- ▶ Equipped with drawers to accommodate ISO standard modules, can also be adapted for modules and modular baskets in heights of 50/100/200 mm.
- ▶ Drawers mounted on telescopic rails with soft closing.
- ▶ Bar structure for installation of various accessories.
- ▶ Standard colour: White aluminium, colour scheme using coloured drawer handles in red RAL 030 40 60.
- ▶ Available in various heights.
- ▶ Accessories can be freely selected from the accessories list starting on page 104.



CPR board (rear side)

Basic version of the emergency trolley

- ▶ Infusions holder.
- ▶ Lead seal on drawers.
- ▶ Holder for oxygen bottles.
- ▶ CPR board on the rear wall of the trolley.
- ▶ Colour: Red RAL 030 40 60.

Modular and versatile: MPO dressing trolley

With the MPO dressing trolleys you are optimally equipped for every application. Whether for dressing tasks or for use as a universal trolley, the MPO models offer the best possible manoeuvrability and optimal use of space due to their compact design.





MPO dressing trolley Type 1

- ▶ MPO 0.5 ISO transportation trolley.
- ▶ Equipped with drawers for half-modules in 50/100 mm, can be pulled out separately, with soft closing.
- ▶ Drawers mounted on telescopic rails with soft closing.
- ▶ Optionally with drawer stop.
- ▶ Bar structure for installation of various accessories.
- ▶ Standard colour: White aluminium, individualised colour design using coloured drawer handles.
- ▶ Central element can be supplied in a different colour as a special version.
- ▶ Available in various heights.
- ▶ Accessories can be freely selected from the accessories list starting on page 104.



MPO dressing trolley Type 2

- ▶ MPO 0.5 ISO transportation trolley.
- ▶ Equipped with drawers for half-modules in 50/100 mm, can be pulled out separately, with soft closing.
- ▶ Drawers mounted on telescopic rails with soft closing.
- ▶ Corner posts for attachment of accessories.
- ▶ Optionally with drawer stop.
- ▶ Standard colour: White aluminium, individualised colour design using coloured drawer handles.
- ▶ Central element can be supplied in a different colour as a special version.
- ▶ Available in various heights.
- ▶ Accessories can be freely selected from the accessories list starting on page 104.

Perfect for daily ward rounds: MPO IT trolleys.

MPO ward trolleys for notes/IT trolleys in ISO standard are indispensable helpers during the daily ward rounds. They keep patients' notes to hand at all times, in electronic form or in hard copy, as a patient file. Our extremely versatile MPO IT trolleys can be used for laptops, PCs and other IT peripheral devices.



Efficient and mobile working.

Elegant design with space for everything needed during digital nursing rounds.



MPO IT trolley Type 1



MPO IT trolley Type 2



MPO IT trolley Type 3



MPO IT trolley Type 4

The ZARGES MPO nursing-rounds trolley combines tried-and-tested logistics modular systems with high-performance IT.

- ▶ The standardised modules can be combined in a variety of ways and adapted to the needs where ever deployed.
- ▶ The trolley is designed to be used with the commonly used ISO module systems.

- ▶ The trolley is designed to be used with the commonly used ISO module systems.
- ▶ The system offers space for everything needed for providing nursing care.
- ▶ Extensive accessories complement the MPO nursing-rounds trolley

A versatile range of accessories for modular nursing and organisation trolleys.

In addition to a wide range of tried and tested standard models, all MPO transportation trolleys can be tailored to your everyday needs. You can easily add and remove accessories on your own without the need for any tools.





Corner post		Order no.	Dimensions, L × W × H, mm
	For attachment of accessories 350 mm long	46099	∅ 30
Material: Anodised aluminium			

Standard rail, side		Order no.	Dimensions, L × W × H, mm
	For end face, for trolley depth 400 mm	46488	565 × 40 × 105
	For end face, for trolley depth 600 mm	46490	765 × 40 × 105
Material: Stainless steel			

Standard rail for rear panel		Order no.	Dimensions, L × W × H, mm
	For rear side, for trolley depth 400 mm	46169	687 × 40 × 98
Material: Stainless steel			

Bar structure		Order no.	Dimensions, L × W, mm
	To accommodate accessories, mounted on worktop, for trolley depth 400 mm	46418	662 × 560
Material: Anodised aluminium and stainless steel			

Standard rail for bar structure		Order no.	Dimensions, L × W × H, mm
	To accommodate accessories, extension for bar structure, for trolley depth 400 mm	46494	670 × 31 × 47
Material: Stainless steel rail with plastic clamp			

Extension set for bar structure		Order no.	Dimensions, L × W × H, mm
	To accommodate accessories, extension for bar structure	46497	236 × 500 × 34

Universal dispenser, 500 ml with drip tray		Order no.	Dimensions, L × W × H, mm
	Aluminium housing, stainless steel pump with short arm lever	46153	103 × 194 × 286

Document holder		Order no.	Dimensions, L × W × H, mm
	Hooks onto the standard rail	46253	350 × 100 × 315
Material: Plastic, white			

Glove holder, single		Order no.	Dimensions, L × W × H, mm
	For attachment of glove box	46168	145 × 125 × 250
Material: Plastic-coated steel			

Glove holder, triple		Order no.	Dimensions, L × W × H, mm
	For attachment of 2 and 3 glove boxes	46170	276 × 978 × 415
Material: Plastic-coated steel			

Wire glove holder, triple		Order no.	Dimensions, L × W × H, mm
	Hooks onto the standard rail	46331	260 × 205 × 395
Material: Plastic-coated steel			

Glove holder, single		Order no.	Dimensions, L × W × H, mm
	Hooks onto the standard rail	46332	157 × 267 × 130
Material: Powder-coated steel			

Closed waste collection system with knee-operated mechanism		Order no.	Dimensions, L × W × H, mm
	With flip-top, 12 l With flip-top, 20 l	46229 46496	254 × 248 × 423 410 × 170 × 400
Material: Plastic-coated steel			

Open waste collection system		Order no.	Dimensions, L × W × H, mm
	Without lid, 12 l Without lid, 20 l	46163 46487	240 × 219 × 393 410 × 170 × 395
Material: Plastic-coated steel			

Holder for half-module		Order no.	Dimensions, L × W × H, mm
	For permanent mounting.	46439	450 × 360 × 80
Material: Steel, plastic-coated, silver			

Recyclables collector 8 L		Order no.	Dimensions, L × W × H, mm
	Knee operated, for hooking in	46297	220 × 220 × 360
Material: Plastic			

Retaining ring	Order no.	Dimensions, L × W × H, mm
 <p>For cannula disposal box, hooks onto standard rail</p> <p>Material: Powder-coated steel</p>	46335	145 × 130 × 160

Holder for cannula box	Order no.	Dimensions, L × W × H, mm
 <p>To accommodate cannula disposal box</p> <p>Material: Plastic-coated steel</p>	46152	100 × 70 × 150

Zip box holder, triple	Order no.	Dimensions, L × W × H, mm
 <p>Hooks onto the standard rail</p> <p>Material: Plastic-coated steel</p>	46333	180 × 349 × 573

Wire basket for standard rail	Order no.	Dimensions, L × W × H, mm
 <p>Hooks onto the standard rail</p> <p>Material: Powder-coated steel</p>	46334	128 × 405 × 146

Syringe dispenser	Order no.	Dimensions, L × W × H, mm
 <p>For mounting on bar structure</p> <p>3 transparent chutes 4 transparent chutes 5 transparent chutes</p> <p>Material: Plastic, grey</p>	46364 31004595 46365	600 × 198 × 228 600 × 207 × 245 600 × 136 × 164

Syringe dispenser (FIFO)	Order no.	Dimensions, L × W × H, mm
 <p>For mounting on bar structure</p> <p>3 transparent chutes 5 transparent chutes</p> <p>Material: Plastic, grey</p>	46348 46349	600 × 200 × 245 600 × 135 × 165

Catheter racks	Order no.	Dimensions, L × W × H, mm
 <p>Hooks onto the standard rail</p> <p>Material: Polished stainless steel</p>	46391	162 × 95 × 560

1 set of lifting hooks	Order no.	Dimensions, L × W × H, mm
 <p>For information boards</p>	46247	70 × 30 × 70

Work platform, folding, HPL		Order no.	Dimensions, L × W × H, mm
	For trolley depth 400 mm	46489	502 × 408 × 35
Material: HPL plastic, silver			

Work platform, folding, ABS		Order no.	Dimensions, L × W × H, mm
	For trolley depth 400 mm	46154	522 × 400 × 45
Material: ABS plastic, silver			

CPR board		Order no.	Dimensions, L × W × H, mm
	Mounted on rear side, for trolley depth 400 mm	46491	730 × 500 × 6
Material: HPL plastic, light grey			

Holder for oxygen bottles		Order no.	Dimensions, L × W × H, mm
	For mounting on profiles on the end face	46492	130 × 110 × 290
Material: Steel, plastic-coated, silver			

Instrument tray with lid slot		Order no.	Dimensions, L × W × H, mm
	Instrument tray with bracket for hooking onto standard rail	46493	455 × 300 × 130
Material: plastic			

Holder for x-ray envelopes		Order no.	Dimensions, L × W × H, mm
	For 15 compartments	46339	600 × 350 × 197
Material: Plastic-coated steel			

Storage plate with pivot arm		Order no.	Dimensions, L × W, mm
	For mounting on profiles on the end face	46495	434 × 313 (Size of storage plate)
Material: Steel, plastic-coated, silver			

Infusions holder		Order no.	Dimensions, Ø × H, mm
	For mounting at position of corner post	46381	Ø 25 × approx. 570
Material: Chrome-plated steel			

Ordering and planning has never been easier with the ZARGES Medical Configurator



Design your MPO transportation and storage trolley according to your requirements using the ZARGES Medical Configurator.

Excellent 360° visualisation enables quick and simple in-house agreement on a configured product.

A drawing and quote for the configuration will then be instantly issued.

Configure your products now:
medical.zarges.com



Digital locking systems – impeccable security for any requirement.



Our solution to meet your needs.

- ▶ Our digital locking systems are open solutions. This means existing systems and key cards can be integrated without any issues.
- ▶ Effortless installation and commissioning.
- ▶ All essential information and access rights are stored on a key card.
- ▶ Scalable according to needs and organisation size – from simple solutions that operate without software to software-enabled full solutions.
- ▶ Activity logging can be enabled.
- ▶ Existing locking systems and key cards can continue to be used.



Many systems, one solution.

Packages

Package 1 “Standalone solution”

The lock can be programmed using a master card without any software – this solution is suitable for small buildings. Any changes to the locking system (for example, in the event of the loss of a key card) must be made directly on the lock itself. The system can be retrofitted with programming capability and software at any time.

Package 2 “Island solution”

The solution for greater overview: A smart software application is used to allow programming to be done using a laptop. Data is transferred using a wireless communication device or an update terminal. The locks are not integrated into the overall access control.

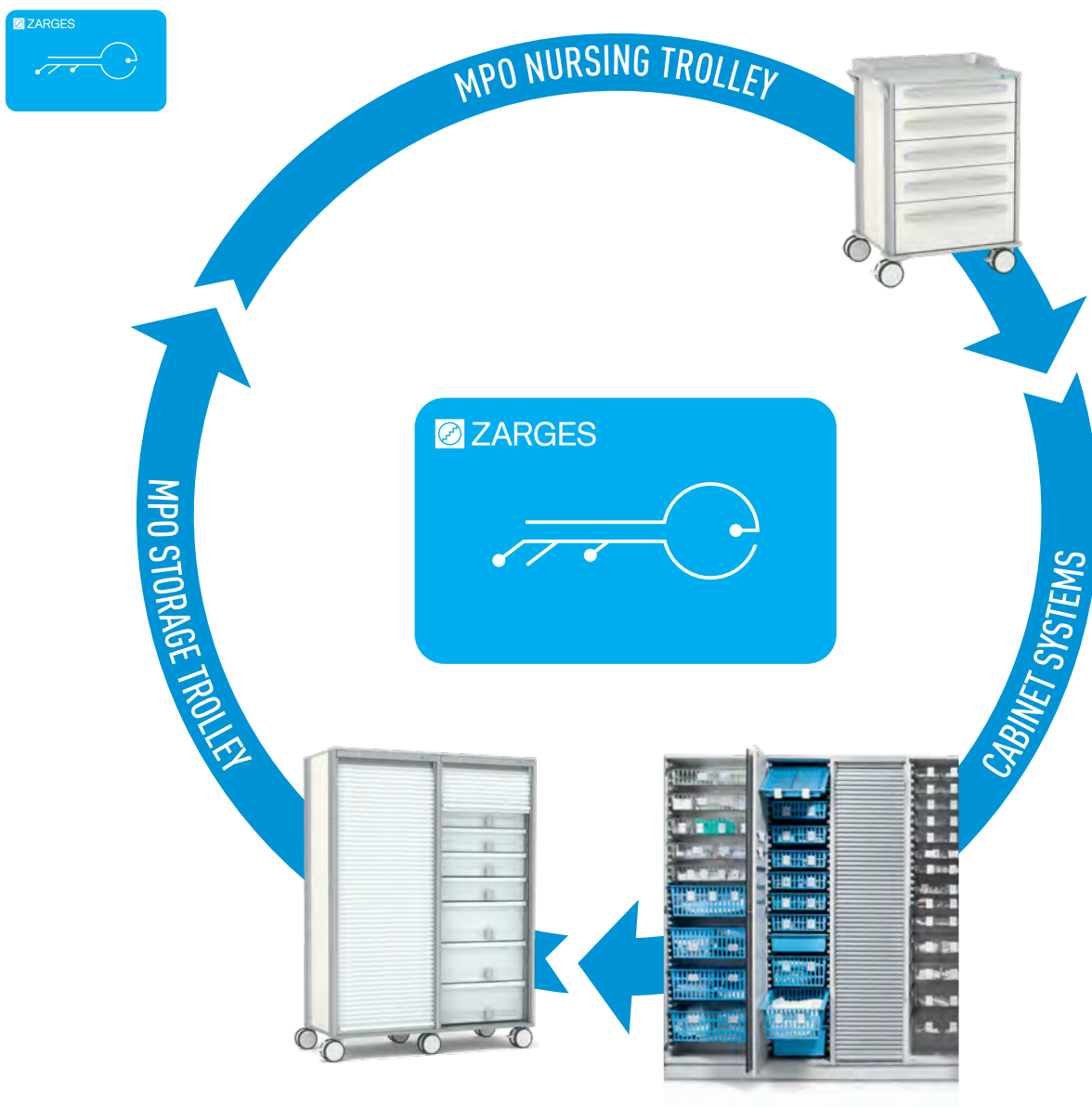

Package 3 “All-in-one solution”

The comprehensive solution: A terminal is used to ensure individual staff members always have up-to-date access rights; this should ideally be combined with access control or time tracking. Data is stored on a key card and transmitted to the terminal at the end of a workday. This allows you to retrace who has used which cabinet.

When good organisation is essential: Multi-function trolleys.

When it comes to protected transport, clearly laid-out storage or a smooth material flow, our multi-function trolleys are universal helpers as you go about your everyday work. Flexible, robust, intelligently designed.



Maximum flexibility – everything on hand.



Multi-function trolley for hook-on insert rails

- ▶ Steel, plastic-coated, hygienic and easy to clean.
- ▶ Colour: Light grey, RAL 7035.
- ▶ Ergonomic handle, anodised aluminium.
- ▶ 4 swivel castors, \varnothing 100 mm, 2 with brakes.
- ▶ Insert rails to be ordered separately.

Order no.	Designation	Dimensions, L x W x H, approx. mm	MATERIAL
46440	Slide-in unit 600 x 400 mm, Slide-in units vary according to module height	765 x 485 x 1100	Steel, plastic-coated, light grey, RAL 7035
46054	Insert rail 400 mm, straight installation	-	-

Further accessories such as HPL worktop and standard rail on request.

Accessories:

362667/HPL worktop suitable for 46440

Efficient and innovative –
from storage to transport.



The medication distribution cycle.

New solutions are required for a more efficient distribution of medication in the healthcare sector. And these solutions need to be future-oriented and intelligent. Based on the ISO standard, the ZARGES system supports nursing staff in the execution of their daily tasks.

The ZARGES solutions offer the ideal products for:

- ▶ Clearly arranged storage.
- ▶ Efficient preparation.
- ▶ Safe transport.
- ▶ Reliable distribution.



Dispensing

Medication boxes



Preparing

Centralised or decentralised preparation station



Distributing

Needs-based distribution using the MPO medication trolley



Transportation

Safe and hygienic transport



Storage

Storage and needs-based sorting of the medication distribution system

For reliable distribution of medication and storage of small parts (e. g. implants).



Medication distribution system

- ▶ With medication boxes for 7+1 days.
- ▶ All medication boxes can be removed individually and fixed in position on the tray.
- ▶ Daily medication for up to 8 patients can be prepared.
- ▶ The distribution tray is based on the ISO standard and can be stored both in the modular cupboard and in the modular distribution trolley on support systems (support wall and telescopic rail), including safety stop system.

Medication module

- ▶ For storing and preparing medication.
- ▶ Fits ZIP boxes with handles.
- ▶ The medication module is based on the ISO standard and can be stored both in the modular cupboard and in the modular distribution trolley on support systems (support wall and telescopic rail), including safety stop system.
- ▶ ZIP boxes are to be ordered separately.
- ▶ ZIP box accessories on page 107.

Order no.	Designation	L × W × H, mm
46179	Complete set	600 × 370 × 44

Order no.	Designation	L × W × H, mm
31001179	Medication module ABS	600 × 400 × 50

Comprises

Order no.	Designation	L × W × H, mm
46178	Medi-Box grey	66 × 23 × 18
46177	Medi label holder	314 × 62 × 5.5
46176	Medi sliding cover, PC	62 × 19 × 32.5
46175	Medi divider set, blue	62 × 19 × 32.5
46174	Distribution tray for medication	600 × 364 × 36

Accessories

Order no.	Designation	L × W × H, mm
383166	ZIP box with handle	355 × 87 × 69
383167	ZIP box with handle	374 × 90 × 119
383168	ZIP box with handle	355 × 130 × 69
383169	ZIP box with handle	374 × 137 × 119

Accessories

Order no.	Designation	L × W × H, mm
46173	Medi divider set, red	62 × 19 × 32.5
46172	Medi label sheet	29.7 × 210 × 0.1
46171	Medi central opening device	650 × 400 × 75

Individual parts can be ordered separately

Organisation made easy.

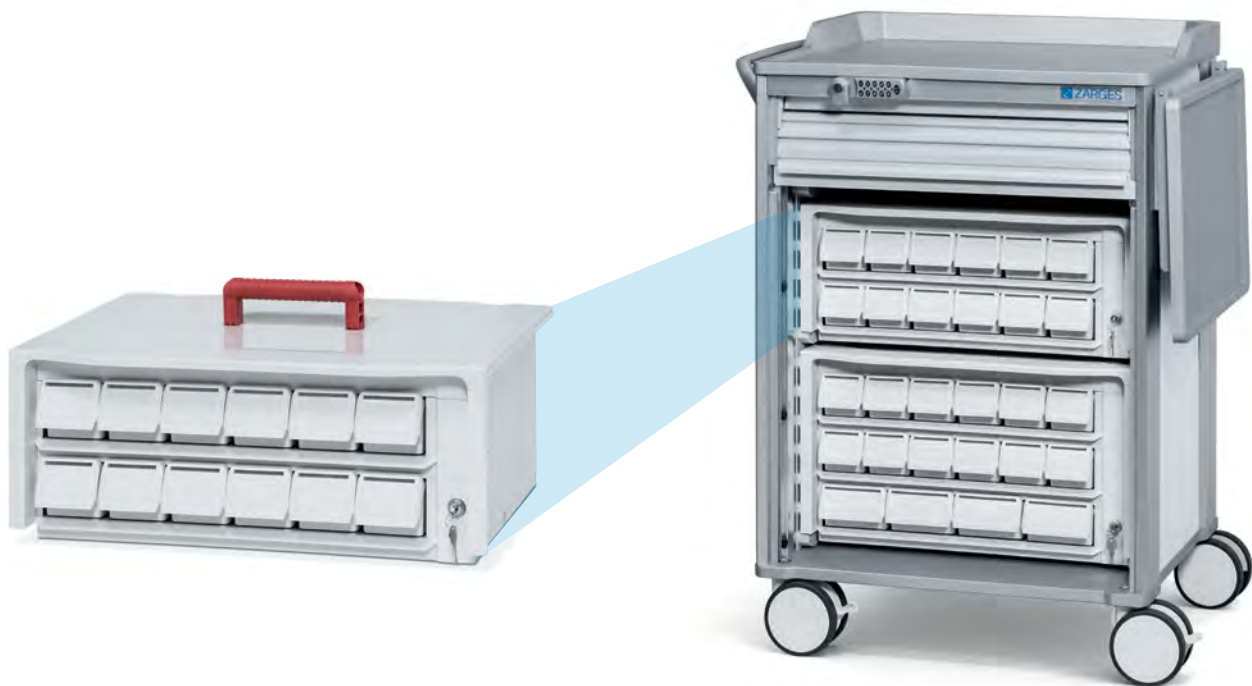

Medication cassette

- ▶ Outside dimensions in accordance with ISO standard 3394.
- ▶ Lockable, keyed alike
- ▶ For insertion on support wall with 400 and 600 mm insertion width.
- ▶ Removable.
- ▶ Designed to hold medication containers.
- ▶ Can be loaded variably.
- ▶ Made from ABS plastic.
- ▶ Medication container to be ordered separately.
- ▶ Medication cassettes double- and triple-row optionally with Digilock.



Single-row

Double-row

Triple-row

Order no.	Designation	L × W × H, mm
46583	Medication cassette, single-row	600 × 400 × 148
46584	Medication cassette, double-row	600 × 400 × 244
46585	Medication cassette, triple-row	600 × 400 × 340
46587	Medication container	338 × 120 (L × W)
46586	Medication container	338 × 80 (L × W)
46588	Divider for medication container 46586	80 (W)
46589	Divider for medication container 46587	120 (W)

Well prepared and reliably distributed: Pharmacy shelving for medications.



Pharmacy shelving

- ▶ Mobile workstation for the simple preparation of medication.
- ▶ Hygienic, easy to clean.
- ▶ Height adjustment with removable insert rails.
- ▶ Steel, plastic-coated.
- ▶ Light grey, RAL 7035.
- ▶ 4 swivel castors, Ø125 mm, 2 with brakes.



367453



372012



372014



378191

Order no.	Designation	L × W × H, mm
367453	For 8 × shelf compartment	1,392 × 475 × 1,900
372012	For 8 × shelf compartment	970 × 475 × 1,900
372014	For 7 × shelf compartment with worktop on telescopic rails	970 × 475 × 1,900

Medication container to be ordered separately.

Medication container

Order no.	Designation	L × W × H, mm	Matching dividers
46180	ZIP box	324 × 87 × 65	46181
46182	ZIP box	324 × 130 × 65	46183
46184	ZIP box	345 × 90 × 115	46185
46186	ZIP box	345 × 136 × 115	46187
383166	ZIP box with handle	355 × 87 × 69	46181
383167	ZIP box with handle	374 × 90 × 119	46185
383168	ZIP box with handle	355 × 130 × 69	46183
383169	ZIP box with handle	374 × 137 × 119	46187

Sensible and practical: Accessories.



ZIP boxes

- ▶ Variably dividable submodule.
- ▶ Fits ISO modules 600x400 mm.
- ▶ Material: ABS.
- ▶ Colour: Light grey.
- ▶ Can be used as a medication supply box or for clear storage of implants.

No.	Order no.	Designation	Dimensions, L x W x H, approx. mm	Matching dividers
1	46180	ZIP box	324 × 86.5 × 64.5	46181
2	46182	ZIP box	324 × 129.5 × 64.5	46183
3	46184	ZIP box	344.5 × 89.5 × 114.5	46185
4	46186	ZIP box	344.5 × 135.5 × 114.5	46187

Medication container

- ▶ Variably dividable submodule.
- ▶ Fits pharmacy shelving and medication cassette.
- ▶ Material: ABS.
- ▶ Colour: Light grey.
- ▶ Can be used as a medication storage and supply box.

Order no.	Designation	Dimensions, L x W x H, approx. mm	Matching dividers
383166	ZIP box with handle	355 × 87 × 69	46181
383167	ZIP box with handle	374 × 90 × 119	46185
383168	ZIP box with handle	355 × 130 × 69	46183
383169	ZIP box with handle	374 × 137 × 119	46187



Accessories: Label holder plate

- ▶ Material: PC, transparent.
- ▶ Dimensions: 60x40 mm.

Order No. 46025



Pharmacy shelving with medication containers



Medical

Transport systems

Universal products for the protected transport of medical goods.

.....

Product overview	122–123
W 105 N cupboard trolley	124–129
Interior fittings for cupboard trolleys	130
Accessories for cupboard trolleys	131
W 170/W 171/W 172 box trolleys	132–136
Accessories for box trolleys	137
Spring-loaded trolley	138–139
Driverless transport systems	140–141
Electric drive assist	142–143
Cage trolleys	144



W 105 N cupboard trolley for laundry transport



W 171 transport trolley for waste transport



W 161 spring-loaded trolley for ergonomic working



W 105 N cupboard trolley for laundry supplies



W 105 N cupboard trolley for transportation and storage of materials



W 105 N cupboard trolley for operational areas



Internal supply with the W 105 N cupboard trolley

Every detail matters when it comes to designing our aluminium equipment containers

The multifunctional trolley for protected, safe and hygienic storage and rational transportation of laundry, medication, expendable and durable goods. The user groups include

hospitals, clinics, laundries, industry, the catering trade and public authorities.



Perfectly equipped for a hard day's work.



W 105 N cupboard trolley

1 Trolley top. Equipped with a front bumper as standard, bumper can be added at the back if required, and suitable for transport by lorry. **2 Peripheral door seal.** Between the body and the door leaves, suitable for cleaning in washdown facilities and provides protection against dust. **3 Ergonomic handle.** Made from ergonomically shaped aluminium profile. **4 Door lock.** Ergonomically shaped and can be fitted with a lead seal, easy-to-operate lever with locking function at the top and bottom ensures reliable closing, suitable for transport by lorry. **5 Bumper.** Abrasion- and disinfectant-resistant plastic padding, easy to replace. **6 Chassis.** 2 swivel and 2 fixed castors, corner-mounted, easy running, rubber wheels, "non-marking", roller bearings, thread guards, wheel brakes optional. **7 Doors.** 2 doors, foldable 270° parallel to the end faces, open doors secured by magnetic catch.

Practical cupboard trolley for fresh laundry, dirty laundry and much more.



W 105 N universal cupboard trolley

- ▶ Aluminium cupboard trolley, anodised, for a wide variety of applications.
- ▶ Smooth interior, no inaccessible areas in washdown facility.
- ▶ Supplied as standard with fixed additional shelf (excluding 41861 and 46862).
- ▶ Optionally with individual interior fittings.
- ▶ Ergonomically shaped handle of anodised aluminium section on the swivel-castor side.
- ▶ Chassis: 2 swivel and 2 fixed castors, corner-mounted, Ø 200 mm, easy-running, non-marking rubber wheels with thread guards.
- ▶ Also suitable for container washdown facilities when used with the appropriate special running-gear castors.



Int. length approx. mm	1,120	1,120	1,250	790
Int. width approx. mm	528	528	620	528
Int. height approx. mm	1,415	1,030	1,415	1,415
Ext. length approx. mm	1,236	1,236	1,366	906
Ext. width, approx. mm	600	600	692	600
Ext. height approx. mm	1,735	1,355	1,735	1,735
Volume, approx. l	837	610	1,090	590
Weight, approx. kg	72	65	84	66
Order no.	46500	46499	46501	46498

The ergonomically designed transport trolleys for sterile, fresh or used, laundry.



W 105 N cupboard trolley for laundry

- ▶ Aluminium cupboard trolley, anodised, for transporting laundry.
- ▶ Smooth interior, no inaccessible areas in washdown facility.
- ▶ 2 additional shelves, bottom shelf can be folded down towards the front, the top shelf towards the rear.
- ▶ Ergonomically shaped handle of anodised aluminium section on the swivel-castor side.
- ▶ Chassis: 2 swivel and 2 fixed castors, corner-mounted, Ø 200 mm, easy-running, non-marking rubber wheels with thread guards.
- ▶ Also suitable for container washdown facilities when used with the appropriate special running-gear castors.

Int. length approx. mm	1,120
Int. width approx. mm	528
Int. height approx. mm	1,415
Ext. length approx. mm	1,236
Ext. width, approx. mm	600
Ext. height approx. mm	1,735
Volume, approx. l	837
Weight, approx. kg	72
Order no.	31011274



W 105 N storage cupboard trolley

- ▶ Aluminium cupboard trolley, anodised, for a wide variety of applications.
- ▶ 1/3 with installation frame for ZARGES ISO-standard modules, slide-in width 400 mm.
- ▶ 2/3 with 2 fixed shelf compartments.
- ▶ Ergonomically shaped handle of anodised aluminium section on the swivel-castor side.
- ▶ Chassis: 2 swivel and 2 fixed castors, corner-mounted, Ø 160 mm, easy-running, non-marking rubber wheels with thread guards.
- ▶ Also suitable for container washdown facilities when used with the appropriate special running-gear castors.



Int. length approx. mm	1,363
Int. width approx. mm	620
Int. height approx. mm	1,253
Ext. length approx. mm	1,479
Ext. width, approx. mm	692
Ext. height approx. mm	1,571
Weight, approx. kg	91.5
Number of insert levels	16
Order no.	31011275

System-conform element of the ZARGES modular system for efficient logistics workflows.



W 105 N modular cupboard trolley

- ▶ Aluminium cupboard trolley, anodised, for a wide variety of applications.
- ▶ Shelf insert for ZARGES ISO-standard modules.
- ▶ Fixed insert rails, ABS support rails ensure that the modules slide easily.
- ▶ Ergonomically shaped handle of anodised aluminium section on the swivel-castor side.
- ▶ Chassis: 2 swivel and 2 fixed castors, corner-mounted, Ø 160 mm, easy-running, non-marking rubber wheels with thread guards.
- ▶ Swivel castors with wheel brakes.
- ▶ Also suitable for container washdown facilities when used with the appropriate special running-gear castors.



Int. length approx. mm	477	920	1,363
Int. width approx. mm	620	620	620
Int. height approx. mm	1,253	1,253	1,253
Ext. length approx. mm	593	1,036	1,479
Ext. width approx. mm	692	692	692
Ext. height approx. mm	1,540	1,540	1,540
Volume, approx. l	370	710	1,055
Weight, approx. kg	43.0	64.0	75.0
Number of insert levels	1 × 8	2 × 16	3 × 8
Order no.	46607	46608	46609

Simple, safe and hygienic transport and storage.



W 105 N modular cupboard trolley with rolling tambour door

- ▶ Space-saving opening through rolling tambour door.
- ▶ Lockable with digital lock.
- ▶ Slide-in width 600 mm.
- ▶ Interior fittings: ZARGES ISO modules can be installed variably, mounted on support wall.
- ▶ Ergonomically shaped handle of anodised aluminium section on the swivel-castor side.
- ▶ Chassis: 2 swivel and 2 fixed castors, corner-mounted, \varnothing 160 mm, easy running, rubber wheels, "non-marking", with thread guards.
- ▶ Swivel castors with wheel brakes.



Int. length approx. mm	699
Int. width approx. mm	520
Int. height approx. mm	1,379
Ext. length approx. mm	815
Ext. width, approx. mm	592
Ext. height approx. mm	1,655
Weight, approx. kg	57.0
Number of insert rails	1 × 23
Order no.	31011276



W 105 N modular cupboard trolley with support wall

- ▶ Aluminium cupboard trolley for modular supply.
- ▶ Interior fittings: ZARGES ISO modules can be installed variably, mounted on support wall.
- ▶ Ergonomically shaped handle of anodised aluminium section on the swivel-castor side.
- ▶ Chassis: 2 swivel and 2 fixed castors, corner-mounted, \varnothing 160 mm, easy-running, non-marking rubber wheels with thread guards.
- ▶ Swivel castors with wheel brakes.



Int. length approx. mm	477
Int. width approx. mm	620
Int. height approx. mm	1,253
Ext. length approx. mm	593
Ext. width, approx. mm	692
Ext. height approx. mm	1,540
Weight, approx. kg	57.0
Number of insert rails	1 × 24
Order no.	31011277

Individualised interior fittings whatever your requirements.



Fixed shelf compartments

For universal applications.



Insert levels for ZARGES ISO standard modules

ABS support rails ensure that the modules slide smoothly.



Folding additional shelves

Safe and ergonomic working, suitable for transporting fresh or dirty laundry as well as waste in bags.



Height of additional shelves adjustable by means of notched rails

Suitable for various packaging sizes.



Removable additional shelves

Shelves can be used as required and cleaned separately.

Accessories and customisation.



Coloured markings

For customising the trolley.



Trolley-top bumper and reinforced corners

For protecting the trolley body during transport by lorry.



Door lock

Available as keyed-alike or keyed-different for secure transport.



Tow bar and coupling for linking and moving trolleys in trains

For in-company transport (up to a maximum of 5 trolleys).



Label frames in various sizes

Simple holder for removable labels.



Special castors

Stainless steel castors with directional lock, central stop and total stop, for a wide range of applications.



Blackboard

For simple labelling on the trolley itself, self-adhesive and rewritable.

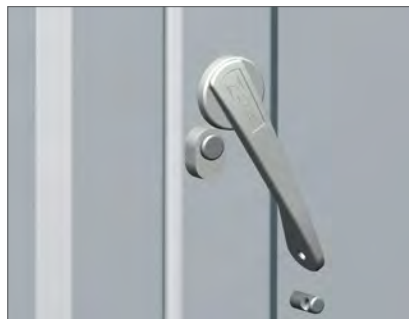

Lead seal

For safeguarding the container against unauthorised opening.



Top railing

For preventing items from falling off the trolley top.

ZARGES box trolleys – multifunctional helpers.

For transportation within the company, deliveries to external plants and branches, laundry transport, supply or disposal – there is a ZARGES box trolley for every application.

A wide selection of models and a comprehensive range of accessories make ZARGES box trolleys all-round helpers. Special constructions are available for special applications.



Safe and protected transport – with the W 171 transport trolley.



W 171 transport trolley with 3-part lid

- ▶ 3-part lid folding mechanism with a flap in the front wall.
- ▶ Anodised design.
- ▶ Container cutout with profile-section surround; profile-section joints continuously welded.
- ▶ Sturdy, generously dimensioned edge and base profile sections, high-strength positive locking ensures permanent bonding to jacket and base metal.
- ▶ Smooth walls without beads.
- ▶ Longitudinal seam welded, base joint sealed all round.
- ▶ Trolley base with drainage channel and drain valve.
- ▶ Ergonomic handle on the swivel-castor side.
- ▶ Plastic-padded peripheral bumper frame.
- ▶ Chassis: 2 swivel and 2 fixed castors, corner-mounted, Ø 200 mm, 50 mm wide, easy-running, rubber wheels, “non-marking”, roller bearings, thread guards.

Basic equipment



Drain valve



3-part lid



Bumper frame



Belt strap

Order no.	Inside dimensions, L × W × H, approx. mm	Outside dimensions, L × W × H, approx. mm	Volume, approx. l	Weight, approx. kg
40691	1,000 × 575 × 1,200	1,140 × 685 × 1,490	690	30.0
40692	1,250 × 700 × 1,200	1,390 × 810 × 1,490	1,050	35.0

Getting a good grip: Ergonomic design with large front flap.



Peripheral beading and corner beads



Castors suited to the application

W 171 with fold-down section and beading

- ▶ Sturdy, generously dimensioned edge and base profile sections, high-strength positive locking ensures permanent bonding to jacket and base metal.
- ▶ End and side walls reinforced with peripheral beading and corner beads.
- ▶ One long side with folds down half-way for more convenient loading and unloading.
- ▶ Container cutout with profile-section surround; profile-section joints continuously welded.
- ▶ Flap with bolt retainer and moving holding hinges.
- ▶ Chassis: 2 swivel and 2 fixed castors, corner-mounted, $\varnothing 125$ mm, easy running, rubber wheels, "non-marking", roller bearings, thread guards.

Order no.	Inside dimensions, L × W × H, approx. mm	Outside dimensions, L × W × H, approx. mm	Volume, approx. l	Weight, approx. kg
40633	900 × 500 × 780	950 × 550 × 980	350	20.0
40674	1,250 × 700 × 1,200	1,300 × 750 × 1,400	1,050	33.0

Accessories

Order no.	Designation	Fits
40559	Lid hinged on, with belt strap and 2 snap fasteners	40633
40675		40674



Robust and versatile: For transporting laundry or waste.



Peripheral beading and corner beads



Castors suited to the application

W 170 transport trolley

- ▶ Sturdy, generously dimensioned edge and base profile sections, high-strength positive locking ensures permanent bonding to jacket and base metal.
- ▶ End and side walls reinforced with peripheral beading and corner beads.
- ▶ Chassis: 2 swivel and 2 fixed castors, corner-mounted, Ø 125 mm, 40 mm wide, easy-running, rubber wheels, "non-marking", roller bearings, thread guards.
- ▶ Casing joint riveted throughout, frame profile sections welded.

Order no.	Inside dimensions, L × W × H, approx. mm	Outside dimensions, L × W × H, approx. mm	Volume, approx. l	Weight, approx. kg
40631	1,000 × 640 × 650	1,050 × 690 × 855	415	19.5
40635	1,250 × 700 × 750	1,300 × 750 × 955	655	23.7

Other chassis configurations available on request

Accessories

Order no.	Designation	Fits
40654	Lid hinged on, with belt strap and 2 snap fasteners	40631
40675		40635



Sturdy aluminium trolley for a wide variety of applications.



W 172 transport trolley

- ▶ Sturdy, generously dimensioned edge and base profile sections, high-strength positive locking ensures permanent bonding to jacket and base metal.
- ▶ End and side walls reinforced with peripheral beading and corner beads.
- ▶ One long side with cutout section, approx. 1,230 × 295 mm.
- ▶ Container cutout with profile-section surround; profile-section joints continuously welded.
- ▶ One ergonomic handle at either end.
- ▶ Chassis: 2 swivel and 2 fixed castors, corner-mounted, Ø 125 mm, 40 mm wide, easy-running, rubber wheels, "non-marking", roller bearings, thread guards.



W 170 plus transport trolley

- ▶ Anodised, edge profile reinforced with abrasion resistant plastic padding.
- ▶ Sturdy, generously dimensioned edge and base profile sections, high-strength positive locking ensures permanent bonding to jacket and base metal.
- ▶ End and side walls reinforced with peripheral beading and corner beads.
- ▶ Chassis: 2 swivel and 2 fixed castors, mounted in tilt arrangement, Ø 100/125 mm, rubber wheels, "non-marking", roller bearings, easy running, thread guards.

Order no.	Inside dimensions, L × W × H, approx. mm	Outside dimensions, L × W × H, approx. mm	Weight, approx. kg	Volume, l
40634	1,500 × 900 × 700	1,650 × 950 × 980	945.0	37

Order no.	Inside dimensions, L × W × H, approx. mm	Outside dimensions, L × W × H, approx. mm	Weight, approx. kg	Volume, l	Castors Ø
40695	1,270 × 700 × 600	1,325 × 750 × 805	25.0	540	125
40696	1,000 × 600 × 590	1,050 × 650 × 770	19.0	350	100

Accessories and special equipment.



Tow bar with coupling

- ▶ Folds upwards.
- ▶ Firmly attached towing device.
- ▶ Tow bar arm approx. 450 mm
- ▶ Tow bar eye 25 mm



Chassis/castors

- ▶ Ø 125 mm, 40 mm wide.
- ▶ Ø 160 mm, 40 mm wide.
- ▶ Ø 200 mm, 50 mm wide.
- ▶ On request, also available in stainless steel for containerwashdown facilities.



Centre pivot

- ▶ Ø 40 mm.
- ▶ For lift-tilt device.



Brake for swivel castors



Ergonomic handle

- ▶ Made from anodised aluminium section.



Peripheral bumper

- ▶ Plastic-padded.



Divider panel

- ▶ To separate different materials.
- ▶ Optional: fixed or movable.



Order Numbers on request

They make your work easier: Spring-loaded trolleys for the catering trade, laundries and storage and retrieval areas.

The up and down movable floor means loading and unloading heights always remain in the same ergonomic and back-friendly position.

This enables efficient working and protects the health of your employees.



W 162 spring-loaded trolley

- ▶ With three versions of central spring.
- ▶ Constant working height thanks to up and down movement of floor.
- ▶ Easy manoeuvring in confined spaces thanks to centrally mounted castors.
- ▶ Anodised.
- ▶ Chassis: 2 swivel and 2 fixed castors, \varnothing 125 mm, 40 mm wide, easy-running, non-marking rubber wheels with roller bearings. On request, the chassis can be configured for mounting castors at the corners.

Order no.	Inside dimensions, L × W × H, approx. mm	Outside dimensions, L × W × H, approx. mm	Volume, approx. l	Spring force, approx. kg	Maximum load, approx. kg	Weight, approx. kg
40748	1,010 × 420 × 431	1,058 × 468 × 785	182	25	100	23
40749	1,010 × 650 × 457	1,058 × 698 × 811	300	45	150	29
40750	1,410 × 700 × 553	1,458 × 748 × 907	545	65	150	34

Spring-loaded trolley with adjustable load capacity.

Thanks to our simple adjustment mechanism, quick adaptation to your individual needs and different loads is guaranteed at all times.

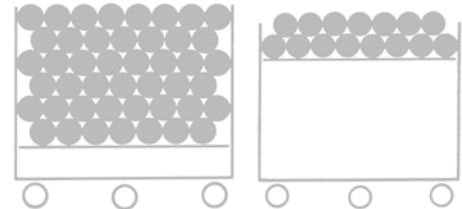

(1) Constant working height



(2) Replaceable lifting elements

W 161 spring-loaded trolley

- ▶ Sturdy, generously dimensioned edge and base profile sections, high-strength positive locking ensures permanent bonding to side walls.
- ▶ Anodised, edge profile reinforced with abrasion resistant plastic padding.
- ▶ Trolley base can be moved vertically, ensuring that the contents are always kept at a constant height (1).
- ▶ Depending on the type of trolley, the load capability can be varied from 30 to 195 kg in increments of 15 kg by means of replaceable lifting elements.
- ▶ The moveable base does not tilt even when loaded on only one side (2).
- ▶ Chassis: 2 swivel and 2 fixed castors, \varnothing 125 mm, 40 mm wide, easy running, rubber wheels, "non-marking", roller bearings, thread guards.
- ▶ Castors arranged centrally for easy manoeuvring even in the most confined spaces.
- ▶ Corner-mounted chassis available on request.

Variant: Spring-loaded trolley with step

The combination of a spring-loaded trolley with a step stool is particularly suitable for use in industrial storage and retrieval work. Project-specific fabrication to meet your requirements.

Order no.	Inside dimensions, L × W × H, approx. mm	Outside dimensions, L × W × H, approx. mm	Volume, approx. l	Weight, approx. kg	Set for loading kg
40644	1,010 × 650 × 485	1,060 × 710 × 820	315	24.5	90
40645*	1,010 × 420 × 460	1,060 × 470 × 800	195	21.0	30
40646	1,010 × 600 × 460	1,060 × 650 × 800	280	25.0	45
40756	1,410 × 700 × 580	1,460 × 750 × 920	570	31.5	150

* Chassis: 4 corner-mounted swivel castors

ZARGES trolley solutions for driverless transport systems (FTS).

FTS trolley solutions are used in hospital logistics to autonomously transport different types of goods and materials. Our special solutions are complemented by customised trolley designs with customer support in the planning phase.

The modular design of ZARGES transport trolleys enables easy adaptation with the standard FTS vehicles.



Transport trolleys for FTS driverless transport systems.



ZARGES e-mobility – quicker and easier to transport.

Electric drive assist systems lower stress and increase productivity by reducing the effort required to push and pull internal transport equipment.



E-mobility – the innovative solution for a wide range of tasks

Electrical drive wheels can now be fitted to the following ZARGES product groups: cupboard trolleys, MPO storage trolleys and storage and retrieval trolleys.



The advantages:

- ▶ Reduced work stress.
- ▶ Decrease in work-related injuries/occupational illnesses.
- ▶ Increase in employee productivity.

Areas of application:

- ▶ Mainly indoors.
- ▶ On level surfaces/floors

Operating time:

- ▶ Operating time depends on many different factors, such as speed, load, number of stop and starts

Operating time example:

- ▶ 80 stop and starts over an 80 m distance=3.2 km, load approx. 300 kg

Tested according to Machinery Directive 2006/42/EC and CE marked.

Product groups



Aluminium cupboard trolley



MPO storage trolley



Storage and retrieval trolley

Simply practical: Combined fresh- and dirty-laundry trolleys.



GW 1700 with tensioning straps

GW 1700 cage trolley

- ▶ Galvanised steel, yellow chromate coating.
- ▶ Tubular-frame chassis mounted on top.
- ▶ Side walls, rear wall and base made from sturdy wire mesh.
- ▶ Upper base can be folded backwards, middle base can be folded to the front.
- ▶ Front section with low wall and crosspiece.
- ▶ Identification plate 100 × 130 mm.
- ▶ Clothes rail, 3 tensioning straps, footplates.
- ▶ Compartment height when bases are folded down: bottom compartment 650 mm, centre compartment 560 mm, top compartment 320 mm.
- ▶ Chassis: 2 swivel and 2 fixed castors, corner-mounted, Ø125 mm, 40 mm wide, easy-running, rubber wheels, "non-marking", roller bearings, thread guards.
- ▶ Protective covers on request.

Order no.	Inside dimensions, L × W × H, approx. mm	Outside dimensions, L × W × H, approx. mm	Weight, approx. kg
43910	740 × 540 × 1,530	800 × 600 × 1,730	37.0





Medical

Supply & disposal

Products for the safe and hygienic supply and disposal of recyclables, laundry and sterile goods.

.....

Product overview	148–149
CIC trolley systems for sterile areas	150–153
Hazardous goods packaging	154–155
Waste collection systems	156–157
Laundry collection system	158
Accessories for laundry collection system	159



Laundry disposal



Car-in-Car sterile goods transport trolley



ZARGES K 470 with approval for dangerous goods transport



Waste collection system "Genius" with clamping ring and pedal mechanism



ZARGES K470 for safe and hygienic storage



Sterile goods supply with the Car-in-Car system

Ergonomically optimised workflows in the sterile goods cycle make your work easier.

The seamlessly integrated Car-in-Car system from ZARGES streamlines operations for the supply and disposal of sterile goods containers.





Car-in-Car: Systematic and sterile transportation.



Car-in-Car W 105 N transport trolley (6 STE)

- ▶ Sturdy body made from anodised aluminium.
- ▶ Central door locking, ergonomically shaped and can be fitted with a lead seal, easy-to-operate lever with locking function at the top and bottom ensures reliable closing, suitable for transport by lorry.
- ▶ The peripheral door seal between the body and the door panels is suitable for washdown facilities and provides protection against dust.
- ▶ Stainless steel chassis, easy running.
- ▶ Brackets for securing the internal trolley inside the outer trolley.
- ▶ Docking device for locking on the front side, for transfer trolley.



Order no.	Designation	Inside dimensions, L × W × H, mm	Outside dimensions, L × W × H, mm	Weight, kg
46590	Car-in-Car W 105 N transport trolley (6 STE)	1,120 × 620 × 1,253	1,260 × 700 × 1,550	67.0

Car-in-Car: Components for the operating-theatre area.



ISO internal trolley (3 STE)

- ▶ Made from stainless steel 1.4301.
- ▶ Surfaces glass-bead peened.
- ▶ Accommodates components of the ZARGES ISO modular system and sterile containers.
- ▶ Maximum exploitation of space in the internal trolley via variable arrangement of the insert rails.
- ▶ Outer dimensions: L×W×H, 456×600×1,171 mm.

Order No. 46591



ISO transfer trolley

- ▶ Made from polished stainless steel 1.4301.
- ▶ Tight docking, including locking mechanism, to cupboard trolley and ISO platform, ensures safe transfer of the ISO internal trolley.
- ▶ User-friendly release of the locking mechanism on the ergonomic handle.
- ▶ 4 stainless steel swivel castors, suitable for container washdown facilities, Ø 125 mm, 2 of which with brakes, for very easy transport and simple handling.
- ▶ Outer dimensions: L×W×H, 575×710×962 mm.

Order No. 46592



CIC insert rail

- ▶ Made from polished stainless steel 1.4301.
- ▶ Height can be adjusted without the use of tools.
- ▶ For storage of shelf compartments and the ZARGES ISO modular system.
- ▶ Outer dimensions: L×W×H, 32×598×67 mm.

Order No. 46594



ISO shelf compartment, CIC

- ▶ Made from polished stainless steel 1.4301.
- ▶ Perforated.
- ▶ To be placed on insert rails.
- ▶ Outer dimensions: L×W×H, 405×598×10 mm.

Order No. 46595



ISO platform

- ▶ Made from polished stainless steel 1.4301.
- ▶ Brackets for securing the internal trolley on the ISO platform.
- ▶ Docking device for locking on the front side, for transfer trolley.
- ▶ Outer dimensions: L×W×H, 686×683×346 mm.

Order No. 46593

ZARGES hazardous goods containers meet a wide range of requirements.

Legislators have laid down strict safety regulations for the packaging and transport of hazardous goods. Hazardous goods may only be transported in packaging that meets

these criteria and is approved by the relevant authorities. ZARGES has many decades of experience with UN-approved containers made of aluminium.

CUSTOMER + ZARGES

Consultation and packaging conception (internal and external packaging)

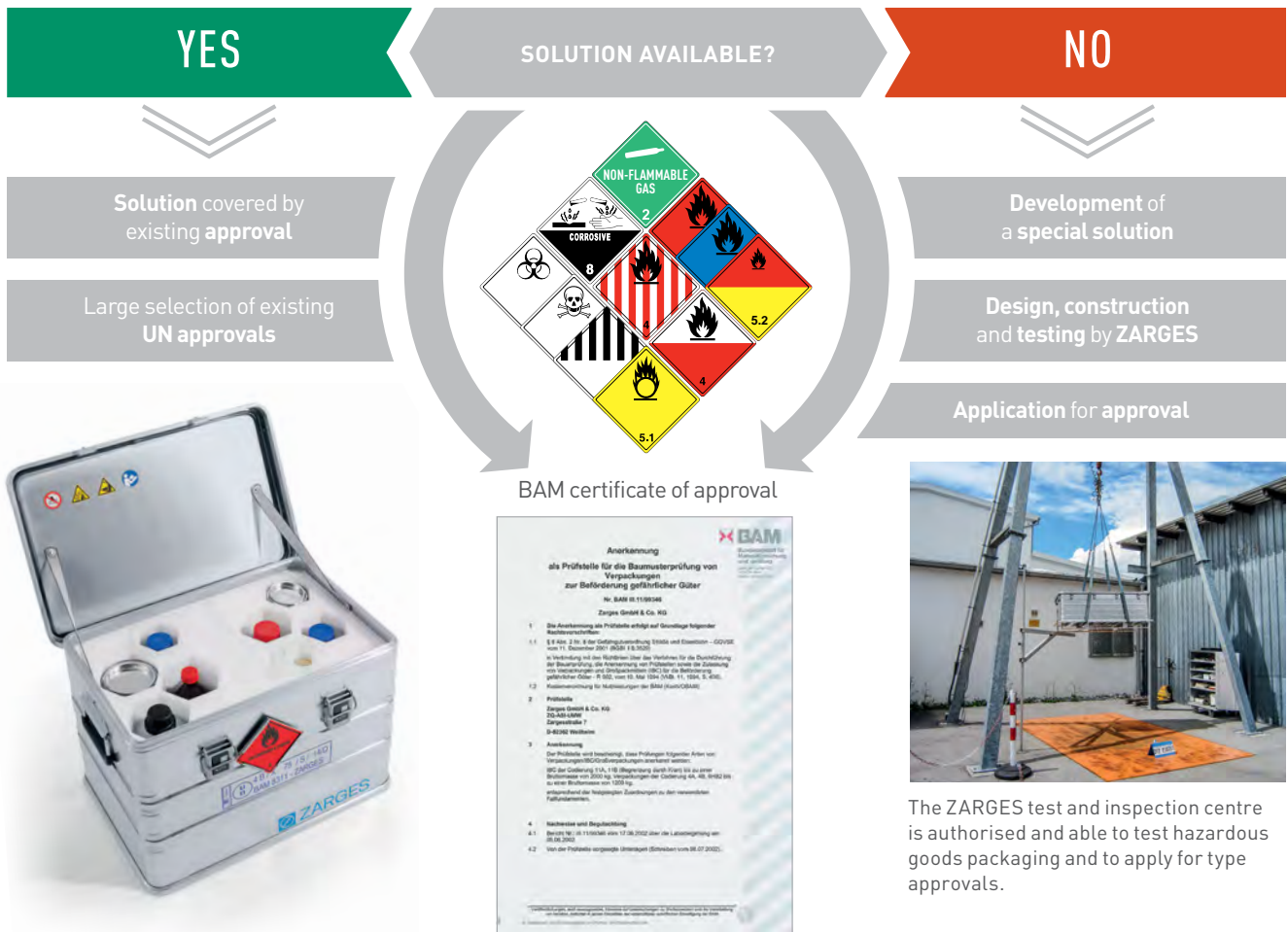

The ZARGES product range

The wide range of standard products is generally able to offer a variety of solutions meet even the most demanding of requirements. Here, in addition to the K 470, you will find an selection from our main product series:



K 470



W 105 N
cupboard trolley



Reusable transport
container UN 3291



Hazardous goods containers for potentially contagious material of Category 6.2.



ZARGES hazardous goods containers are approved as composite packaging for the transport of potentially contagious substances in accordance with UN numbers 2814 and 2900, Category A and B, with any transport operator. The containers have passed more-stringent tests, such as drop tests from a height of 9 m. All sizes in the K 470 series can be used for the transport of UN number 3373. Dry ice or other coolants can be used for temperature-controlled transport.

Cupboard trolley with UN approval for the use of UN 3291

Contaminated surgical instruments are transported between hospitals and external service providers for disinfection and preparation. Due to the risk of infection, these objects are defined as hazardous goods of class UN 3291 (clinical waste).



Zip-seal bag

- ▶ With easy-to-operate slide-type seal for quick and simple opening and closing.
- ▶ Mandatory for infectious substances which must be packed in accordance with transport regulations P620 or P650.
- ▶ Material: PE, thickness 100 µm.

Order No. 43831



K 470 with approval for Class 6.2

- ▶ For substances with UN numbers 2814 and 2900.
- ▶ Container has passed stringent tests, including a drop test from a height of 9 metres.

Order No. 342856



Insulating container

- ▶ Compatible with K 470 with inside dimensions, L × W × H, 350 × 250 × 310 mm.
- ▶ For temperature-controlled transport.
- ▶ Can also be used with dry ice.

Order No. 40677

Collection and transport – well thought-out in every detail.

Whether you need a system for collecting and transporting laundry, recyclables or waste: ZARGES offers high-quality, ergonomically designed products for every step. Hygienic, easy to clean and well planned, right down to the smallest detail.



The practical helpers as you go about your everyday work: Waste collection systems.



Stainless steel waste collection system “Kompakt”

- ▶ Polished stainless steel frame.
- ▶ All tube connections fully welded.
- ▶ Bag fitting rings each with SR 400 rubber ring.
- ▶ 4 swivel castors, \varnothing 75 mm, easy-running castors.
- ▶ With hinged lid and plastic floor pan.

Order no.	Designation	Dimensions, L x W x H, approx. mm
NA71	1-compartment collection station	420 x 530 x 950
NA72	Double-compartment collection station	620 x 530 x 950
NA73	Triple-compartment collection station	970 x 530 x 950
NA74	4-compartment collection station	1,320 x 530 x 950

Waste collection system “Genius” with clamping ring and pedal mechanism

- ▶ Stainless steel frame.
- ▶ All tube connections fully welded.
- ▶ 1 step bar.
- ▶ 4 buffers.
- ▶ 4 swivel castors, \varnothing 75 mm, 2 of which with stopper.
- ▶ Optional: Fixed feet at the front, 2 swivel castors, \varnothing 75 mm, at the rear.

Order no.	Chassis/substructure	Volume, approx. l	Dimensions, L x W x H, approx. mm
S40	2 swivel castors/2 fixed feet	40	580 x 525 x 825
S70	2 swivel castors/2 fixed feet	70	580 x 525 x 1,010
S40L	4 swivel castors	40	580 x 525 x 825
S70L	4 swivel castors	70	580 x 525 x 1,010

Optional accessories

- ▶ TVD pedal mechanism.
- ▶ Buffers.



Pedal mechanism for hinged lid

Ergonomically designed and practical: Stainless steel laundry collector "Kompakt".



NW71



TW1



TW2

Stainless steel laundry collector "Kompakt"

- ▶ Polished stainless steel frame.
- ▶ All tube connections fully welded.
- ▶ Bag fitting rings each with SR 400 rubber ring.
- ▶ Suitable for textile and plastic bags or mesh laundry bags.
- ▶ 4 swivel castors, \varnothing 75 mm, 2 of which with easy-running castors with stopper.

Textile laundry bags

- ▶ 100% polyester.
- ▶ Hold approx. 12 kg of laundry.
- ▶ Boil-proof and durable.
- ▶ Self-opening through sewn-on toggle fastener.
- ▶ 2 horizontal coloured stripes.



NW72



NW73



NW74

Order no.	Designation	Dimensions, L × W × H, approx. mm
NW71	1-compartment collection station	420 × 540 × 930
NW72	2-compartment collection station	620 × 530 × 940
NW73	3-compartment collection station	970 × 530 × 940
NW74	4-compartment collection station	1,320 × 530 × 940

Order no.	Designation	Dimensions, L × W, mm	Colours
TW1	Laundry bag, white, 2 coloured stripes	575 × 1.000	Red, yellow, green, blue, brown, grey
TW2	Laundry bag, coloured	575 × 1.000	Red, yellow, green, blue, brown, grey
WTW2	Laundry bag, waterproof	575 × 1.000	Bright yellow or blue

To make your work easier: Practical accessories.



Plastic lid (KDH)

Lid with hook, in various colours.

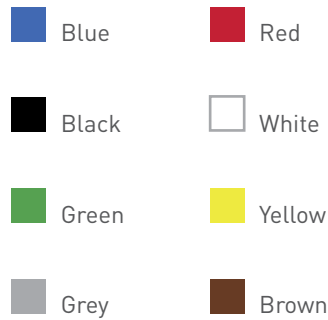

Lid colours for KDH + KDS



Plastic lid (KDS)

Lid with plastic hinge and soft closing, in various colours.



Single-compartment wall-mounted collector (NW10)

With wall holder.



Pedal mechanism (TVD)

Pedal mechanism for hinged lid.



Plastic floor pan (KBW)

Plastic floor pan for laundry collector, available for single- to 4-compartment model.

Order no.	Designation	Dimensions, L × W, mm	Attachment
KDH	Plastic lid	425 × 292	Hook
KDS	Plastic lid	425 × 292	Plastic hinge with soft closing
NW10	Single-compartment wall-mounted collector	390 × 330 × 325 (L × W × H)	-
TVD	Pedal mechanism	-	-
KBW	Plastic floor pan	-	-



Medical Packaging

Optimum packaging solutions with ZARGES cases
and accessories.

Product overview	162-163
K 424 XC	164-165
K 470 universal container	166-167
Interior fittings	168-170
Accessories	171



ZARGES has the right interior fittings for every packaging task.



Approved for UN 2814 using 9-metre fall tests



Sturdy aluminium cases offering perfect organisation for emergency medical and disaster relief services



Safe packaging for the transportation of biological samples



K 424 XC with integrated castors and telescopic handle



Flexible mobility for all K 470 models with clip-on castors that can be fitted without the use of tools



For safe transportation of instrument containers in precisely tailored foam insert



Order no. 43825: Insulation insert suitable for the use of dry ice



Ergonomic transportation with the K 424 XC



ZARGES K 470 with approval for the transportation of highly infectious materials



K 470: hygienic and safe transport

K 424 XC mobile box – mobile and ergonomic in use

The requirements placed on a mobile box vary as widely as those of the people who use them. So how does the ZARGES K424 XC manage to meet all these needs?

Hospitals and clinics, the mobile nursing sector and emergency medical services? The answer is simple. It is reduced to the essentials: optimum protection, the highest level of mobility, minimum weight and ergonomic design.

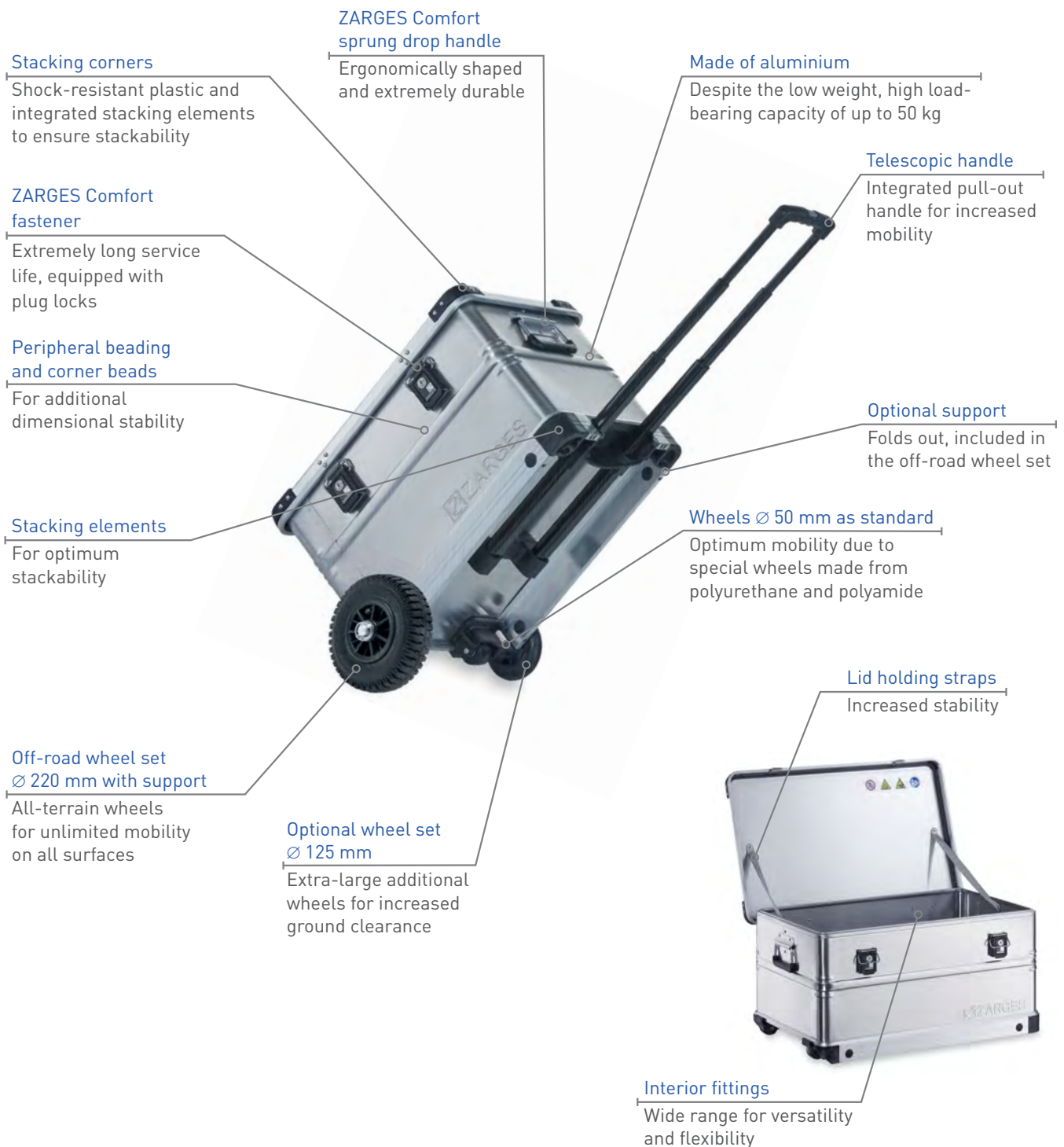

Unlimited mobility – it's smooth running on any surface when you have the right wheels.



Order no.	Inside dimensions, L × W × H, approx. mm	Outside dimensions, L × W × H, approx. mm	Volume, l	Weight, kg	Pull handle	Max. Total weight, kg
41810	516 × 350 × 159	550 × 400 × 233	28	6.3	3-part	25.0
41811	550 × 350 × 310	600 × 400 × 385	60	7.3	3-part	25.0
41812	750 × 350 × 380	800 × 400 × 455	99	9.0	2-part	35.0
41813	750 × 450 × 310	800 × 500 × 385	105	9.5	2-part	35.0
41814	750 × 635 × 410	800 × 685 × 485	195	12.0	2-part	35.0
41815	910 × 350 × 380	960 × 400 × 455	120	9.5	2. Sprung drop handle	50.0

Sizes and dimensions

Choice of 6 models in standard sizes. Their capacity ranges from 28 to 195 l.



Castor set \varnothing 125 mm

- ▶ Set of wheels with solid rubber tyres and plastic rims.
- ▶ Increases ground clearance to 50 mm.
- ▶ With high-quality ball bearings and plug-in axles.
- ▶ Can be retrofitted to any K424 XC without tools and at the touch of a button.
- ▶ Includes storage bag made from hard-wearing nylon fabric.
- ▶ Bag can be fixed in position.
- ▶ Wheels and axle can be fitted and removed without the use of tools.



Off-road wheel set \varnothing 220 mm

- ▶ Mobility even in tough and difficult terrain.
- ▶ High-quality air tyres, \varnothing 220 mm.
- ▶ Increases ground clearance to 65 mm.
- ▶ Easy-to-fit support feet allow the product to be put down horizontally.
- ▶ Wheels and axle can be fitted and removed without the use of tools.

Order no.	Suitable for boxes	Wheel diameter, mm
41818	All K 424 XC	125

Order no.	Suitable for boxes	Wheel diameter, mm
41819	41811, 41812, 41815	220
41832	41813	220
41833	41814	220

1 case – 1,000 possibilities.

As a standard product or a customer specific solution, the ZARGES K470 is always the perfect choice for the most exacting requirements. Sensitive medical equipment, safe transport of medicine or urgently required foreign aid: The classic K 470 aluminium case from ZARGES offers

perfect protection for everything you need – even under extreme conditions. A comprehensive range of system accessories ensures that you have the optimum packaging solution whatever the task in hand.



K 470 universal container

- ▶ High-quality aluminium universal box.
- ▶ Lid with stainless steel hinge strip, two lid straps and all round foamed seal.
- ▶ Stacking corners made from cast aluminium.
- ▶ High level of stability due to 3 fully-welded aluminium profile frames.
- ▶ Profile-section joints fully welded.
- ▶ Beading all round and corner beads for additional dimensional stability.
- ▶ Extra thick 1.5-mm sheet metal for all K470 containers from basic dimensions 750 × 550 mm.
- ▶ Ergonomic heavy-duty sprung drop handles.
- ▶ ZARGES Comfort handles for ergonomic handling and loads of up to 50 kg.
- ▶ Ergonomically designed and durable Comfort fasteners for at least 20,000 operating cycles.
- ▶ Can be secured with a plug lock, lead seals, catch spring retention (anti-opening feature) or a padlock (max. shackle thickness 6 mm).
- ▶ 25 standard sizes, customised sizes on request.

The right container for all requirements!

With a range of 25 models, the K 470 series offers a unique selection of standard sizes. Their capacity ranges from 13 to 829 l.

And if you can't find the box you need in this range, ZARGES can also make special sizes to your order.

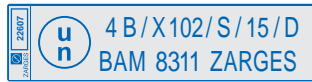

All sizes also available with approval for the transportation of hazardous goods



Order no.	See No.	Inside dimensions, L × W × H, approx. mm	Outside dimensions, L × W × H, approx. mm	Volume, approx. l	Weight, approx. kg	With approval for the transportation of hazardous goods, max. permissible gross weight, kg	Matching foam lining without installation
40835	1	350 × 250 × 150	400 × 300 × 180	13	2.6	26.0	43860
40677	2	350 × 250 × 310	400 × 300 × 340	27	3.1	58.0	43861
40810	3	550 × 350 × 150	600 × 400 × 180	29	4.2	65.0	43862
40568	4	550 × 350 × 220	600 × 400 × 250	42	4.8	65.0	43863
40678	5	550 × 350 × 310	600 × 400 × 340	60	5.0	70.0	43864
40564	6	550 × 350 × 380	600 × 400 × 410	73	5.3	75.0	43865
40849	7	550 × 550 × 220	600 × 600 × 250	67	5.6	65.0	43866
40859	8	550 × 550 × 380	600 × 600 × 410	115	6.6	75.0	43867
40836	9	550 × 550 × 580	600 × 600 × 610	175	7.8	94.0	43868
40837	10	600 × 430 × 450	650 × 480 × 480	116	6.5	70.0	43869
40839	11	600 × 560 × 440	650 × 610 × 470	148	7.4	83.0	43871
40841	12	690 × 460 × 380	740 × 510 × 410	121	6.9	71.0	43873
40842	13	690 × 640 × 340	740 × 690 × 370	150	8.0	84.0	43874
40843	14	690 × 640 × 430	740 × 690 × 460	190	8.6	100.0	43875
40565	15	750 × 550 × 380	800 × 600 × 410	157	10.0	102.0	43877
40566	16	750 × 550 × 580	800 × 600 × 610	239	12.0	126.0	43878
40844	17	780 × 480 × 520	830 × 530 × 550	195	11.1	103.0	43879
40845	18	900 × 480 × 400	950 × 530 × 430	173	11.0	93.0	43880
40846	19	900 × 640 × 450	950 × 690 × 480	259	13.4	115.0	43881
40567	20	950 × 450 × 380	1,000 × 500 × 410	162	10.9	65.0	43882
40847	21	1,150 × 350 × 150	1,200 × 400 × 180	60	7.5	50.0	43887
40580	22	1,150 × 750 × 480	1,200 × 800 × 510	414	20.0	183.0	43884
40848	23	1,350 × 400 × 220	1,400 × 450 × 250	119	9.5	65.0	43888
40875	24	1,550 × 550 × 465	1,600 × 600 × 495	396	25.0	150.0	43885
40876	25	1,650 × 750 × 670	1,700 × 800 × 700	829	30.0	200.0	43886

Important note: Opening clearance approx. 30 mm smaller than inside dimensions (length and width). Special sizes on request.

Customisable foam inserts



Delivery without content

Regardless of whether they are used for insulation, impact absorption, storage or organisation – our foam inserts are able to provide the greatest protection for high-quality tools and sensitive measuring instruments. The cross-linked PE foam have excellent insulating properties and does not absorb moisture. It is also flexible and extremely durable.

We offer foam inserts that are tailored to our customers' specific needs and applications, ranging from simple linings to multilayer custom-made foam inlays. As well as specifications like colour, texture and appearance, we can take into account requirements such as conductivity, antistatic and flame-retardant properties, and resistance to UV, temperatures, mineral oil or other kinds of chemicals. We'll work closely with you to develop customised packaging that meets your needs. Simply provided us with photos, drawings, digital 3D models or original parts, and you'll receive your packaging solution from a single source.

Your benefits

- ▶ Transport protection, padding and insulation.
- ▶ Insulation and electrostatic protection.
- ▶ Neat and space-saving organisation.
- ▶ Customised foam inserts according to requirements.
- ▶ in-house box and foam production – made in Germany.
- ▶ Complete solution from a single source.



Lining



100% foam (full height)

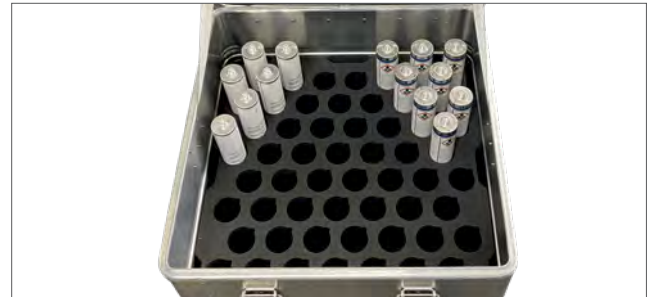

50% foam (half height)



Multilayer



Compartments (structural divider plate)

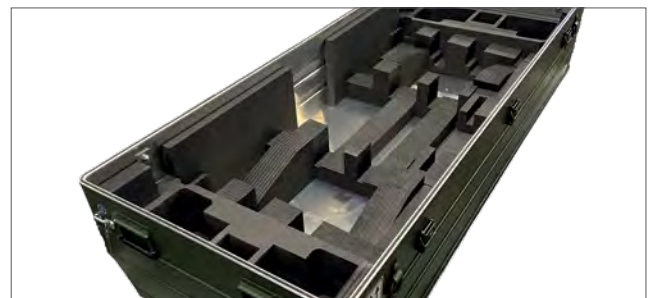

Custom-cut

Getting things sorted.



Inner bag with crosswise divider

- ▶ Robust, water-repellent inside bag made from polyester.
- ▶ Fully sealable with all-round zip fastener.
- ▶ Lateral reinforcement/bracing for easy loading and unloading.
- ▶ Removable, with sturdy carrying handles.
- ▶ Equipped with crosswise dividers that can be fixed in variable positions.

Order no.	Fits	Dimensions, L × W × H, approx. mm	No. of crosswise dividers
41822	K 424 XC: 41810	516 × 350 × 159	4
41823	K 424 XC: 41811, K 470: 40678	550 × 350 × 310	4
41824	K 424 XC: 41812	750 × 350 × 380	6
41826	K 424 XC: 41813	750 × 450 × 310	6
41827	K 424 XC: 41814	750 × 635 × 410	6
41828	K 424 XC: 41815	910 × 350 × 380	6
41829	K 470: 40564	550 × 350 × 380	4
41830	K 470: 40565	750 × 550 × 380	6
41831	K 470: 40566	750 × 550 × 580	6



Lid bag

- ▶ Ideal for laptops, tablet, cables, small parts or documents.
- ▶ Protects parts and keeps order inside the case.
- ▶ Easy assembly.
- ▶ The bag is easily detachable.

Order no.	Designation	Fits cases with inside dimensions from mm	Dimensions, L × W × H, approx. mm
41820	Lid bag, large	550 × 350	420 × 260 × 40
41821	Lid bag, small	310 × 250	260 × 150 × 40

Always a snug fit: Inserts made from Pick 'n Pluck foam.



Pick 'n Pluck foam

Pre-cubed foam is easily removed to create different shapes and depths. The fast and simple solution for individual items or small batches. Layout can be changed without tools. Set includes two sheet thicknesses, lid insert nubby foam 30 mm, base foam 10 mm. Nubby foam in the lid is self-adhesive.

Order no.	Fits	Inside dimensions, L × W × H, approx. mm
40735	40810, 40568	550 × 350 × 220
43854	40678, 40564	550 × 350 × 380
40736	40849	750 × 550 × 220
43856	40565	750 × 550 × 380

The perfect padding: Foam linings for universal protection.



Delivery without content

Foam Lining

Durable and wear-resistant lining comprising of physically cross-linked PE foam for the base and walls (density 40 kg/m³, thickness 11 mm), and convoluted foam for the lid. Easy to fit due to the self-adhesive wall and lid linings. The base lining is simply placed at the bottom.

Order no.	Fits	Inside dimensions, L x W x H, approx. mm
43889	41810	516 x 350 x 159
43864	41811	550 x 350 x 310
43891	41812	750 x 350 x 380
43892	41813	750 x 450 x 310
43893	41814	750 x 635 x 410
43890	41815	910 x 350 x 380



Universal protection, whatever the content



Wide variety of applications

Order no.	Fits	Inside dimensions, L x W x H, approx. mm
43860	40835	350 x 250 x 150
43861	40677	350 x 250 x 310
43862	40810	550 x 350 x 150
43863	40568	550 x 350 x 220
43864	40678	550 x 350 x 310
43865	40564	550 x 350 x 380
43866	40849	550 x 550 x 220
43867	40859	550 x 550 x 380
43868	40836	550 x 550 x 580
43869	40837	600 x 430 x 450
43871	40839	600 x 560 x 440
43873	40841	690 x 460 x 380
43874	40842	690 x 640 x 340
43875	40843	690 x 640 x 430
43877	40565	750 x 550 x 380
43878	40566	750 x 550 x 580
43879	40844	780 x 480 x 520
43880	40845	900 x 480 x 400
43881	40846	900 x 640 x 450
43882	40567	950 x 450 x 380
43884	40580	1,150 x 750 x 480
43885	40875	1,550 x 550 x 465
43886	40876	1,650 x 750 x 670
43887	40847	1,150 x 350 x 150
43888	40848	1,350 x 400 x 220



Peripheral foamed seal in the lid



Protected against water jets

ZARGES K 470 – optionally with protection class IP 65, the dust-tight case that is protected against water jets

- ▶ These cases are used wherever valuable and sensitive equipment needs to be protected against extreme environmental influences.
- ▶ The automatic pressure relief valve with Gore™ membrane ensures that the lid still opens reliably even after changes in the air pressure.
- ▶ The K 470 IP 65 has been successfully tested by TÜV SÜD and certified leak-tight.



To make routine tasks easier: Practical accessories.



Clip-on castors

Mobility for all models from inside dimensions 550 × 350 mm upwards. Can be fitted without using tools.

Made from solid rubber, Ø 100 mm, swivel castors equipped with wheel brakes, load capacity of up to 100 kg on 4 castors.

Order no.	Designation
40741	2 fixed castors, each with a clamping mechanism 1 × left and 1 × right
40742	2 swivel castors, each with a clamping mechanism 1 × left and 1 × right



W 150 dolly trolley

Aluminium chassis, low version.

Chassis: 2 swivel and 2 fixed castors, Ø 125 mm, 40 mm wide, easy running, rubber wheels, "non-marking", roller bearings, thread guards.

Order no.	Fits outside dimensions, L × W, approx. mm
40607	600 × 400
40608	800 × 600



W 152 dolly trolley

Aluminium chassis, high version. H = 450 mm.

Chassis: 2 swivel and 2 fixed castors, corner-mounted, Ø 125 mm, 40 mm wide, easy running, rubber wheels, "non-marking", roller bearings, thread guards.

Order no.	Fits outside dimensions, L × W, approx. mm
40680	800 × 600



Adhesive label for delivery notes

Firm attachment of shipping labels, self-adhesive, easy to clean.

Order no.	Dimensions, L × W, approx. mm
343904	280 × 280

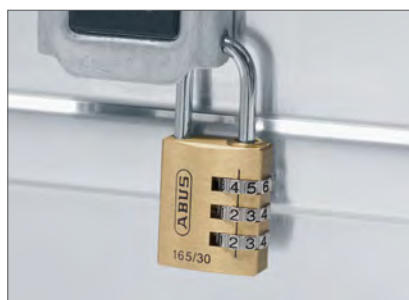

Shackle lock

Shackle lock with 3-digit, freely selectable number combination, shackle diameter 5 mm.

Order no.	Fits
46989	All ZARGES cases



Embossing

In DIN font, capital letters, 20 mm font height, single and multiple lines. On request.

Order no.	Fits
-	All ZARGES cases



Medical Access

Safe working at heights with ZARGES ladders, steps and scaffold units.

.....

Product overview	174-175
Shelf ladders	176-177
Stepladders, single-sided access	178
Stepladders, double-sided access	179
Step stools	180-181
Pax Tower 1T folding scaffold unit	182-183



Bolted stepladder with treads with padded front edges, double-sided access, mobile



Pax Tower folding scaffold unit



Hook-on shelf ladder with treads with padded front edges, in rest position



Safety steps, folding



Hook-on shelf ladder with treads with padded front edges, in position for use



Bolted stepladder with treads and padded front edges, mobile



Mobile step stool

Ideal for use in medical storage areas and medication storerooms.

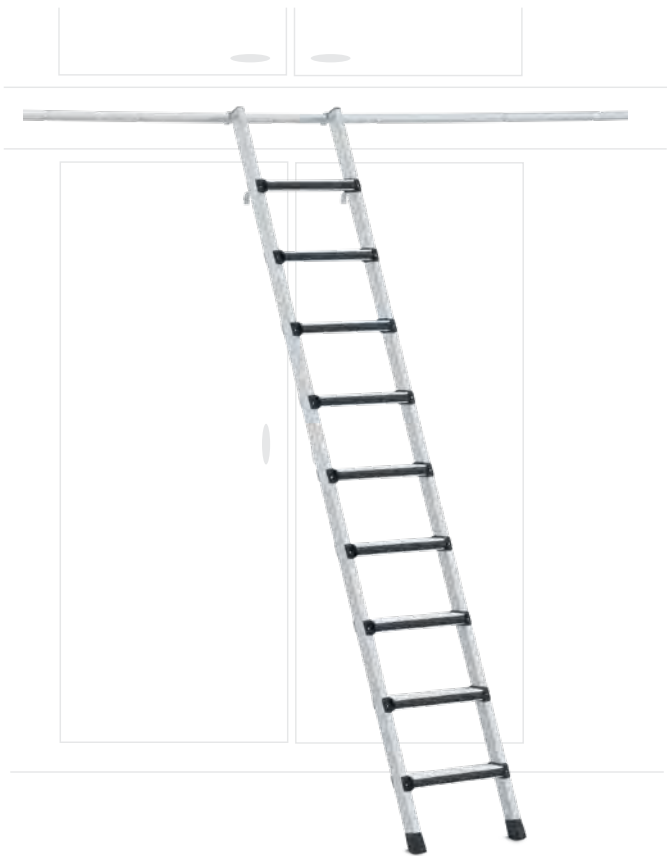

For further tread designs, see www.zarges.com

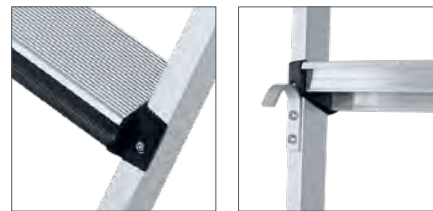

Comfortstep LH, bolted hook-on shelf ladder with treads

- ▶ The shelf ladders have two hooks for the guide rail and additional hooks for vertical storage on the shelf (see A and B).
- ▶ Wear-resistant, anodised stiles.
- ▶ 80 mm deep treads with padded front edges.

Please quote the distance between the floor and the top edge of the tubular rail when ordering!
Can only be used with cupboard with railing front.

Order no.	From/to maximum vertical hook-on height, m	No. of treads
41402	1.45-1.69	6
41403	1.70-1.94	7
41404	1.95-2.19	8
41405	2.20-2.44	9
41406	2.45-2.69	10

Base stand-off = vertical height of the guide rail × 0.404

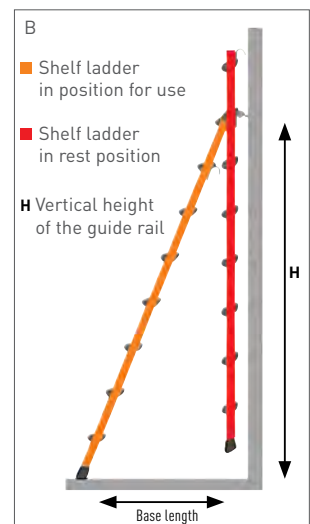
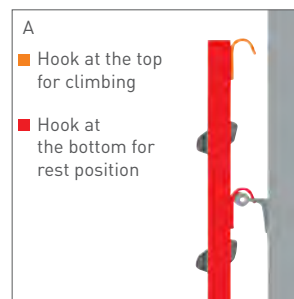

Accessories

Order no.	Tubular rail
40370	Aluminium alloy tube, ∅ 30 mm, 3,000 mm long, anodised
41457	Aluminium alloy intermediate bracket
41458	Aluminium alloy bracket with stop on the right
41459	Aluminium alloy bracket with stop on the left

Rail systems: One intermediate bracket to be provided for each approx. 1.00 m length of tubing.

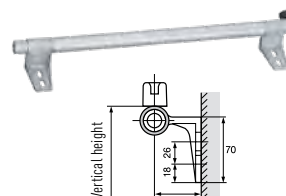

For easy travel backwards and forwards along your shelving:
With guide rails and self-locking sprung castors.



For further tread designs,
see www.zarges.com



Comfortstep Trec LH, bolted shelf ladder with treads, mobile

- ▶ Both the top of the ladder and the self-locking sprung castors at the bottom lock the shelf ladder when weight is applied.
- ▶ When not in use, the ladder can be stowed vertically on the shelf to save space.
- ▶ Wear-resistant, anodised stiles.
- ▶ 80 mm deep treads with padded front edges.

Please quote the distance between the floor and the top edge of the tubular rail when ordering!
Can only be used with cupboard with railing front.

Order no.	From/to maximum vertical hook-on height, m	Number of treads
41412	1.84–2.08	6
41413	2.09–2.33	7
41414	2.34–2.58	8
41415	2.59–2.83	9
41416	2.84–3.08	10

Base stand-off = vertical height of the guide rail × 0.404



Accessories

Order no.	Tubular rail
40370	Aluminium alloy tube, ∅ 30 mm, 3,000 mm long, anodised
41457	Aluminium alloy intermediate bracket
41458	Aluminium alloy bracket with stop on the right
41459	Aluminium alloy bracket with stop on the left

Rail systems: One intermediate bracket to be provided for each approx. 1.00 m length of tubing.

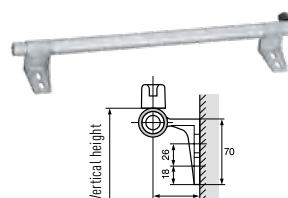

Protection for your shins: high degree of comfort while working with padded treads.



Applies to both ladders



Comfortstep S, bolted stepladder with treads, mobile

- ▶ 80 mm deep treads with padded front edges.
- ▶ Wear-resistant, anodised stiles.
- ▶ Platform made from extruded aluminium (300 mm × 250 mm) for safe and comfortable standing even when working for longer periods of time.
- ▶ Practical aluminium storage tray for small items and tools.
- ▶ High-strength anti-splay strap, from 4 treads.
- ▶ Equipped with 4 sprung swivel castors, Ø80 mm, for added mobility.
- ▶ Added stability thanks to rigid locking bar on both sides.

Comfortstep S, bolted stepladder with treads

- ▶ 80 mm deep treads with padded front edges.
- ▶ Wear-resistant, anodised stiles.
- ▶ platform made from extruded aluminium (300 mm × 250 mm) for safe and comfortable standing even when working for longer periods of time.
- ▶ Practical aluminium storage tray for small items and tools.
- ▶ High-strength anti-splay strap, from 4 treads.

Order no.	Ladder length, m	Platform height, m	Working height, approx. m	Lower, outside width m	Stile height access/ support section, mm	Number of treads incl. platform	Weight, kg
41421/8102	1.52	0.75	2.75	0.50	42 / 42	3	8.2
41422/8102	1.79	1.00	3.00	0.53	42 / 42	4	9.2
41423/8102	2.06	1.25	3.25	0.56	42 / 42	5	10.2
41424/8102	2.33	1.50	3.50	0.59	48 / 42	6	11.5
41425/8102	2.60	1.75	3.75	0.61	48 / 42	7	12.5
41426/8102	2.87	2.00	4.00	0.64	48 / 42	8	13.7
41427/8102	3.40	2.50	4.50	0.70	48 / 42	10	16.2

Order no.	Ladder length, m	Platform height, m	Working height, approx. m	Lower, outside width m	Stile height access/ support section, mm	Number of treads incl. platform	Weight, kg
41421	1.52	0.75	2.75	0.50	42 / 42	3	6.4
41422	1.79	1.00	3.00	0.53	42 / 42	4	7.4
41423	2.06	1.25	3.25	0.56	42 / 42	5	8.4
41424	2.33	1.50	3.50	0.59	48 / 42	6	9.7
41425	2.60	1.75	3.75	0.61	48 / 42	7	10.7
41426	2.87	2.00	4.00	0.64	48 / 42	8	11.9
41427	3.40	2.50	4.50	0.70	48 / 42	10	14.4

Climb without scraping your shins for a high degree of comfort while working and a flexible range of applications.



Applies to both ladders



Comfortstep B, bolted stepladder with treads, mobile

- ▶ 80 mm deep treads with padded front edges.
- ▶ Wear-resistant, anodised stiles.
- ▶ High-strength Perlon straps to prevent splaying.
- ▶ Equipped with 4 sprung swivel castors, \varnothing 80 mm, for added mobility.
- ▶ Added stability thanks to rigid locking bar on both sides.

Comfortstep B, bolted stepladder with treads

- ▶ 80 mm deep treads with padded front edges.
- ▶ Wear-resistant, anodised stiles.
- ▶ High-strength Perlon straps to prevent splaying.

Order no.	Ladder length, m	Working height, approx. m	Lower, outside width m	Stile height, mm	Number of treads	Weight, kg
41432/8102	0.84	2.25	0.44	42	2×3	6.2
41433/8102	1.11	2.50	0.47	42	2×4	7.6
41434/8102	1.38	2.75	0.50	42	2×5	9.1
41435/8102	1.65	3.00	0.53	42	2×6	10.6
41436/8102	1.92	3.25	0.56	42	2×7	12.1
41437/8102	2.18	3.50	0.59	48	2×8	14.0
41438/8102	2.72	4.00	0.65	48	2×10	17.6
41430/8102	2.99	4.25	0.68	48	2×11	19.4

Order no.	Ladder length, m	Working height, approx. m	Lower, outside width m	Stile height, mm	Number of treads	Weight, kg
41432	0.84	2.25	0.44	42	2×3	4.4
41433	1.11	2.50	0.47	42	2×4	5.8
41434	1.38	2.75	0.50	42	2×5	7.3
41435	1.65	3.00	0.53	42	2×6	8.8
41436	1.92	3.25	0.56	42	2×7	10.3
41437	2.18	3.50	0.59	48	2×8	12.2
41438	2.72	4.00	0.65	48	2×10	15.8
41430	2.99	4.25	0.68	48	2×11	17.6

The quick and flexible way to bridge small differences in height.



Bigfoot P, mobile step stool

- ▶ Ribbed, non-slip standing surface.
- ▶ Mobile version with self-locking sprung castors.
- ▶ Extremely stable due to patented automatic locking mechanism and non-slip rubber lip.
- ▶ Platform diameter of 30 cm for safe standing.

Order no.	Platform height m	Working height, approx. m	Diameter, top, m	Diameter, centre m	Diameter, bottom, m	Weight, kg
40918	0.43	2.45	0.29	0.36	0.44	2.6



Plazamax P, safety steps

- ▶ Large standing area: 230×360 mm.
- ▶ Large steps for safe and comfortable standing, with rubber surface.
- ▶ Collapsible for extremely compact dimensions.
- ▶ Safety bar with practical storage tray, optional on the 3-step variant, attached as standard on the 4- or 5-step variant.

Order no.	Platform height, m	Working height, approx. m	Lower, outside width m	Safety bar	Stile height, mm	Number of treads incl. platform	Weight, kg
41927	0.45	2.45	0.48	No	70	2	3.9
41923	0.70	2.70	0.56	No	70	3	6.6
41928	0.70	2.70	0.56	Yes	70	3	8.4
41926	0.90	2.90	0.57	Yes	70	4	10.6
41925	1.15	3.15	0.60	Yes	70	5	12.8

Accessories

Order no.	Designation
41929	Castor set (possible from 3 treads)





PaxTower 1T



One-handed operation of the folding frame featuring a sturdy lock button: Engage or release the lock with simple click. Patented toeboard unit: Quick to install. Smooth-sliding guides made of hard plastic: Prevent misalignment when connecting push-on end frames together.

Technical details

- Scaffold size: 1.80 × 0.72 m
- Stile diameter: 45 mm
- Rung diameter: 45 mm
- Claw type: automatic
- Fits through doorways: Yes
- Wheels with height adjustment: No
- Wheel diameter: 125 mm
- Scaffolding class: 3 (= 200 kg/m²)
- Standard: EN 1004-1

Platform sizes:



	Base pack / Size 1	Size 2	Size 3	Size 4	Size 5	Size 6
Working height m	2.55	3.55	4.55	5.55	6.55	7.55
Scaffold height m	1.65	2.65	3.65	4.65	5.65	6.65
Platform height m	0.55	1.55	2.55	3.55	4.55	5.55

Platform size 0.60 m × 1.80 m						
Weight kg	29.1/38.3	68.0	78.0	95.3	111.2	130.4
Order no.	53510*/53511	53512	53513	53514	53515	53516

*Order No. 53510 (base pack) does not comply with EN 1004-1 for mobile work platforms. The "EN 1004 add-on pack" (order no. 53550) must be ordered in addition to ensure compliance. Ballast weights are not included.

Ballast	Order no.	Number of ballast weights per swivel castor					
Indoor use	42792	1	0	0	0	0	0
Outdoor use		1	0	0	0	1	3

Observe the ballasting requirements in the assembly and usage manual!

Ballast weights not included in the scope of delivery.

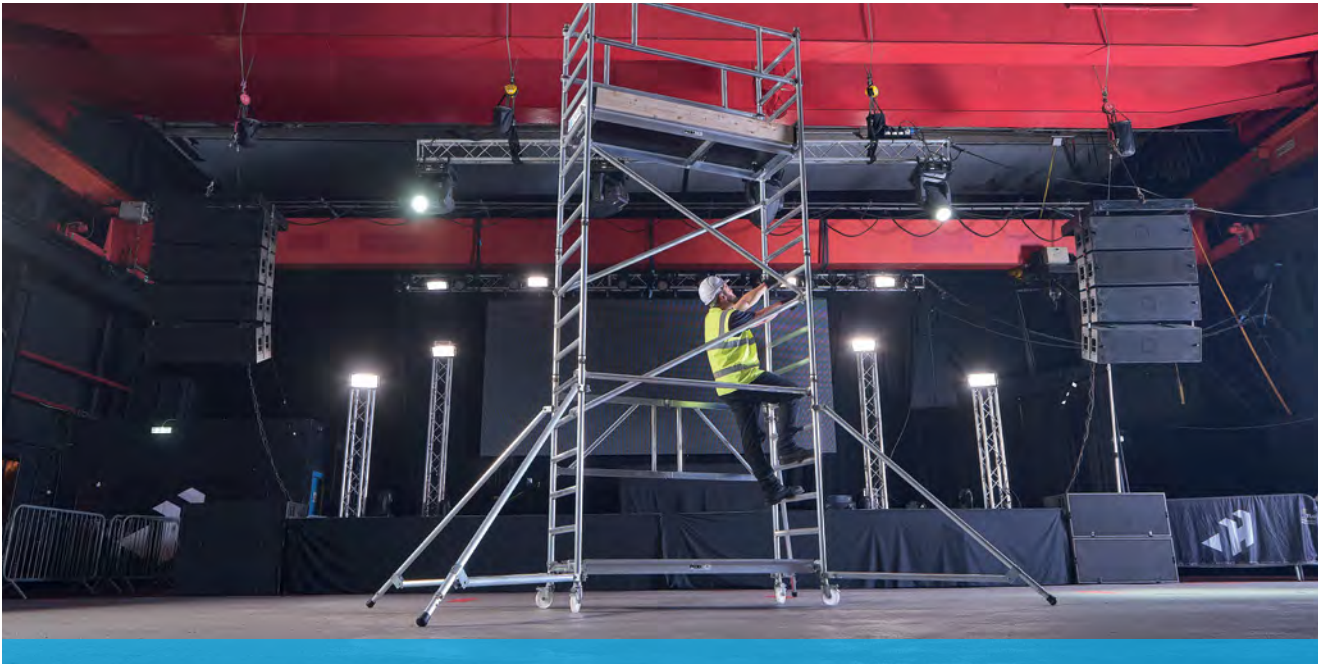

Packs for PaxTower 1T



1T packs	Order no.	Size 1	Size 2	Size 3	Size 4	Size 5	Size 6
Order no.		53511	53512	53513	53514	53515	53516
Base pack	53510	1	1	1	1	1	1
EN 1004 add-on pack	53550	1	-	-	-	-	-
Stabiliser pack	53551	-	1	1	1	1	1
Toeboard pack	53552	-	1	1	1	1	1
One-metre extension pack 1T	53553	-	1	1	1	1	1
Two-metre extension pack 1T	53554	-	-	-	1	1	2
Two-metre add-on frame 1T	53555	-	-	1	-	1	-
Guardrail pack 1T	53556	-	-	-	-	1	1

PaxTower – components and accessories

Note: Please ask us about the delivery times and prices for other components or spare parts where necessary

Swivel castor

Plastic wheel, Ø 125 mm, with lockable pin and brake.
Delivery size: 1 piece.



Weight kg	Order no.
1.3	42790

Ballast weight (cuboid)

Steel, painted. With clamps for attachment to stabilisers.
Colour: Yellow.



Weight kg	Order no.
10.0	42792

Castor adapter

Adapter that can be screwed onto a swivel castor (order no. 42790) to provide height adjustment.
Adjustment range: 6.5 cm.
Delivery size: 1 PU = 4 pieces.



Weight kg	Order no.
3.2	42794



Medical

Information and service

ZARGES Service	186
Additional information Medical	187
The advantages of aluminium	188
ZARGES Medical online	189
Alphabetical index	190
Numerical search index	191–193
General Terms and Conditions	194

ZARGES Service.



Technical recommendations

Our general cleaning recommendations for your ZARGES modular system and aluminium transport trolley are available on request.



Spare parts

A quick and dependable supply of original ZARGES spare parts ensures that your products remain in perfect condition even after many years of use. All original ZARGES spare parts are available in accordance with the legal provisions.

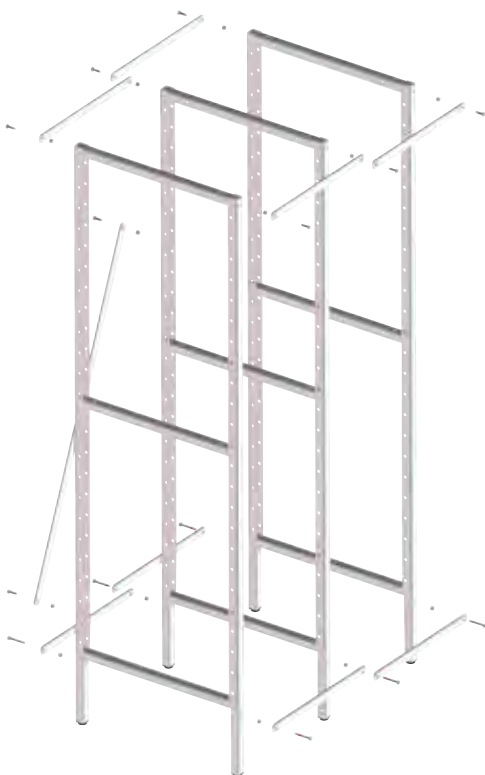

Assembly instructions

Detailed assembly instructions are available on request for self-assembly of all kits and support systems.



Spatial planning

On the basis of logistics workflows and work ergonomics and in accordance with all hygiene standards, we plan facilities which are tailored to the specific requirements of your company in both materials and design. If desired, we can also coordinate the technical processes (see page 4-5).

Additional information Medical.



ISO-standard modules

The ZARGES modular system is based on ISO standard 3394, which specifies a basic size of 600 mm × 400 mm. This standard defines the dimensions (L × W 600 × 400 mm) for rigid, rectangular-shaped transport packaging.



ABS modules

The ISO-standard modules used by ZARGES are manufactured from ABS (Acrylonitrile Butadiene Styrene) plastic. ABS is a thermoplastic. Due to its organic constituents, ABS is

resistant to inorganic media, lactic acids, lyes and aqueous saline solutions. Prolonged contact with organic solvents such as alcohol, acetone and benzene is not recommended. During the cleaning of ABS modules, a max. temperature of 100°C is possible for brief periods. The maximum constant temperature for cleaning is 85°C.



PC modules

ZARGES PC modules are made from PC (polycarbonate) plastic. PC is a polyester. Polycarbonate is a thermoplastic which is naturally transparent but can be dyed. It is

dimensionally stable and has high impact resistance. Polycarbonate is bio-compatible. Polycarbonate is resistant to diluted acids, oils and ethanol, but is not resistant to alkalis, concentrated acids, aromatic hydrocarbons or methanol. Only neutral cleaning agents should be used for cleaning. The use of abrasive scouring agents will scratch the surfaces. During the cleaning of PC modules and parts, a maximum temperature of 135 °C is possible for brief periods. The maximum constant temperature for cleaning is 125 °C.



Soft closing

The drawers of ZARGES MPO trolleys are equipped with soft-closing telescopic rails. The soft-closing system reduces the speed at which the drawer is closed, cushioning the movement.



Notched rail

Used for the variable installation of telescopic rails. The metal rail, which has notches at intervals of 25 mm, is screwed tightly to the inner wall of the cupboard. Variable installation without the use of tools facilitates height adjustment of the telescopic drawers.



Approval for the transportation of hazardous goods

Special hazardous goods packaging (also called 'hazardous goods containments') are used to transport hazardous liquids or solids safely by

land, air or sea. Every hazardous goods packaging requires a type approval which certifies that the containers have been tested for leak-tightness and comply with further specific requirements. In Germany, new approvals are granted exclusively by the Federal Institute for Materials Research and Testing (Bundesanstalt für Materialforschung und -prüfung – BAM). ZARGES is a BAM-certified testing centre and as such, is authorised to test and document its own hazardous goods containments and to apply for approvals for them. ZARGES draws on many decades of know-how in the design and manufacture of hazardous goods packaging.



Anodisation

When it comes into contact with oxygen from the air, the surface of aluminium oxidises. This dense layer of oxide immediately reforms when damaged and protects the metal underneath against corrosion. Under conditions of particular

stress, surface protection can be improved even further by means of anodisation. This material property contributes significantly to the long service life of ZARGES products. Anodisation protects sensitive goods against aluminium abrasion and makes them more suitable for use in washing facilities, thus preventing staining, for example of laundry.



Riveted joints

All riveted joints are produced with full rivets. Where there are exceptionally high loads, high-strength rivets are used to ensure optimum durability at all times.



Safety stop system

The safety stop system prevents drawers with telescopic rails on MPOs tilting. The continuous locking bar prevents several drawers being pulled out at the same time.

The advantages of aluminium as a material – economical, safe, ecologically sensible.



Aluminium is lightweight extremely stable:
The density of aluminium is only approx. 2.6 to 2.8 g per cm³. That is approx. 1/3 the density of steel. In spite of its low weight, aluminium is extremely strong.

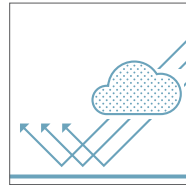

Aluminium is vapour-impermeable:
Even when stored over very long periods of time, moisture will not diffuse through the material. An aluminium container can be welded to make it water-vapour-proof.

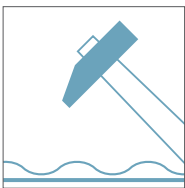

Aluminium is impact-resistant and extremely strong:
Even though the surface may become dented by the force of an impact, the impact energy is absorbed by the deformation.

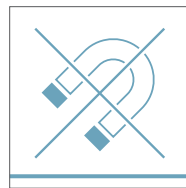

Aluminium is magnetically neutral:
Aluminium is not ferromagnetic. This material characteristic can be of great significance for certain applications.



Aluminium is insensitive even to extreme fluctuations in temperature:
The material characteristics remain constant within a temperature range of -80 to +150 °C.

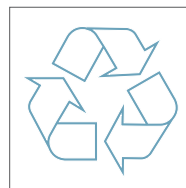

Aluminium is fully recyclable:
Used aluminium can be melted down and re-used – an important contribution towards waste reduction and environmental protection.



Aluminium is corrosion-resistant and protects itself:
When it comes into contact with oxygen, the surface of aluminium oxidises to create an oxide layer that reforms when damaged.

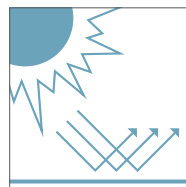

Aluminium is resistant to UV rays:
Large Long periods of storage and exposure to UV rays have no effect on this material.



Aluminium is hygienic:
The smooth surface of aluminium is easy to clean and odourless. Aluminium containers are ideal for use in areas with high hygiene requirements.

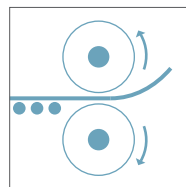

Aluminium can be processed in a wide variety of ways:
All standard processing methods – welding and moulding – can be applied to aluminium and are much more efficient to carry out on aluminium than other metals.

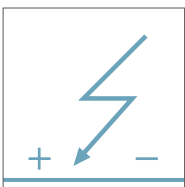

Aluminium is electrically conductive:
Aluminium is a good conductor of electricity and heat, an advantage, for example, for housings for built-in electronic components.

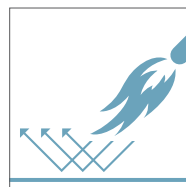

Aluminium is incombustible:
No sparks fly when you strike aluminium materials. Aluminium is non-flammable, and not even aluminium shavings burn.



www.zarges-medical.com

clear, informative, user-friendly.

What you can find at www.zarges-medical.com

- ▶ Product search – quickly find the products you need.
- ▶ Find a sales representative – ZARGES sales representatives near you.
- ▶ Product information – dimensions, materials and functions at a glance.
- ▶ News – all news relating to ZARGES and our products.
- ▶ Resource Center – download catalogues, brochures, assembly and check sheets, watch set-up videos and read application reports.



Almost like a search engine:
At www.zarges-medical.com, you can find out everything about our products and services.

Experience the world of ZARGES

Not just products, but solutions: On our clear and carefully structured website, your ZARGES product is just a few clicks away – with all the facts and additional information on our extensive product range, special constructions and services.



Structured depiction of products:
all product variants at a glance

Alphabetical index

A		
Waste container	163	
ABS catheter holder	33	
ABS modules	16	
ABS modular baskets	16	
Adapter for telescopic rails	31	
General Terms and Conditions	200	
Anaesthesia trolley	97	
Pharmacy shelving	118	
Top mounted cupboards	41	
Safety stop system	21	
B		
Blackboard	131	
Safe for anaesthetics (BTM)	35	
K 470 box	172, 173	
C		
Car-in-Car (CIC)	158	
D		
Blackboard	131	
Tow bar and coupling	131	
Digital locking systems	110–111	
E		
CIC internal trolley	159	
CIC insert rail	159	
Labels (paper and self-adhesive)	23	
Label clip	22, 23	
Label holder	23	
Label strip	23	
Labelling	22, 23	
F		
Shelf compartment for MPO storage trolley	77	
Shelf compartment – cabinet system	34	
Colour range, cupboards	43	
Spring-loaded trolleys	138, 139	
Driverless transport systems (FTS)	140, 141	
G		
Hazardous goods containers	161	
Hazardous goods packaging	160	
Scaffolding, folding scaffold unit	188	
Wire mesh compartment, cabinet system	34	
Cage trolleys	144	
Glass door, cabinet system	26	
Glass door, MPO	74	
H		
Half-module	18	
Wall unit	40	
Tall cupboard	38, 44–46	
Height units, cupboards	37	
I		
Interior fittings for Zarges cases	174	
ISO frame for drawers	34	
IT trolleys	103	
K		
Card lock	110, 111	
Catheter drawer	33	
Catheter rack	32	
ISO catheter magazine	32	
Box	172	
K 470 case	172	
Transparent sleeve	23	
Adhesive labels	23	
Storage and retrieval shelving	50	
Storage and retrieval trolley	66–68	
Refrigerator for medication	35	
Plastic mount for telescopic rails	33	
L		
Storage systems	11	
Ladders	184, 185	
M		
Medication cassettes	117	
Medication distribution systems	114	
Medication trolley	95	
Mobile Zarges K 424 XC case	170	
Module frames for catheter racks	32	
Modular cupboard trolley	128	
Modular drawers	19	
MPO transportation trolley	86–103	
MPO storage trolleys	70–80	
MPO accessories	106–108	
Multifunction insert rails	31	
Multi-function trolley	112–113	
N		
Emergency trolley	99	
P		
PC half-modules	18	
PC modules	17	
PC modular baskets	17	
Nursing trolley	93	
CIC platform	158	
R		
Notched rails	30	
Sterile goods shelf	73	
Shelving	52–65	
Shelf assembly instructions	54–55	
Hook-on shelf ladder for cupboards	182–183	
Steel shelving system	64–65	
Shelving system for Kanban storage	62	
Shelving system for catheter storage	63	
Shelving system for hospital pharmacy	60	
Shelving system for sterile goods	61	
Shelving system ISO standard	59	
Shelf accessories	56–57	
Castor rail for support wall	29	
Rolling tambour door	78	
S		
Foam lining for Zarges cases	174	
Tube holder	33	
Locking systems	110–111	
Cupboard equipment	44–49	
Cabinet system overview	24–25	
Cupboard trolley	124–131	
Sorting trolley	69	
Securing clip	31	
Access technology	178–189	
Sterile transport	156–159	
T		
Dividers	16, 17, 18, 19	
Divider fixing	21	
Telescopic rails for fixed installation	30	
Telescopic rails for variable installation	30	
Support wall	28–29	
Transport systems	120–145	
Transport trolleys	132–137	
Safe	35	
U		
CIC transfer trolley	159	
Lower cabinet	39	
V		
Dressing trolleys	101–101	
Packaging	167	
Supply & disposal	153	
Ward trolley for notes	102	
W		
Trolley for sterile area	158	
Laundry collection system	164	
Laundry transport trolley	127	
Z		
ZIP boxes	119	
Accessories for modules and modular baskets	20–21	
MPO storage trolley accessories	78	
Accessories for cupboard trolleys	131	
Accessories for Zarges cases	177	

Numerical search index

Order No.	Page						
40370	182, 183	41412	183	43860	176	46038	18
40559	134	41413	183	43861	176	46039	18
40564	173	41414	183	43862	176	46040	17, 19
40565	173	41415	183	43863	176	46041	17, 19
40566	173	41416	183	43864	176	46042	17, 19
40567	173	41421	184	43865	176	46043	17, 19
40568	173	41422	184	43866	176	46045	32
40580	173	41423	184	43867	176	46046	32
40607	177	41424	184	43868	176	46047	32
40608	177	41425	184	43869	176	46048	32
40631	135	41426	184	43871	176	46054	68, 113
40633	134	41427	184	43873	176	46059	68
40634	136	41430	185	43874	176	46072	65
40635	135	41432	185	43875	176	46079	65
40644	139	41433	185	43877	176	46080	23
40646	139	41434	185	43878	176	46081	23
40654	135	41435	185	43879	176	46099	105
40674	134	41436	185	43880	176	46118	30
40675	134, 135	41437	185	43881	176	46120	29
40677	161, 173	41438	185	43882	176	46140	64, 65
40678	173	41457	182, 183	43884	176	46141	64, 65
40680	177	41458	182, 183	43885	176	46152	107
40691	133	41459	182, 183	43886	176	46153	105
40692	133	41810	171	43887	176	46154	78, 108
40695	136	41811	171	43888	176	46159	31
40696	136	41812	171	43889	176	46160	31
40735	175	41813	171	43890	176	46161	31
40736	175	41814	171	43891	176	46162	31
40741	177	41815	171	43892	176	46163	106
40742	177	41818	171	43893	176	46168	106
40748	138	41819	171	43910	144	46169	105
40749	138	41820	175	46000	16	46170	106
40750	138	41821	175	46001	17	46171	116
40756	139	41822	175	46002	18	46172	116
40810	173	41823	175	46003	18	46173	116
40835	173	41824	175	46004	17	46174	116
40836	173	41826	175	46005	16	46175	116
40837	173	41827	175	46006	18	46176	116
40839	173	41828	175	46007	18	46177	116
40841	173	41829	175	46010	17	46178	116
40842	173	41830	175	46011	16	46179	116
40843	173	41831	175	46021	18	46180	118, 119
40844	173	41832	171	46022	21	46182	118, 119
40845	173	41833	171	46023	23	46184	118, 119
40846	173	41923	186	46025	23, 119	46186	118, 119
40847	173	41925	186	46026	21	46196	28
40848	173	41926	186	46027	16	46197	28
40849	173	41927	186	46028	16	46198	28
40859	173	41928	186	46029	16, 29	46199	28
40875	173	41929	186	46030	16	46200	16
40876	173	42790	189	46031	17, 19	46201	16
40918	186	42792	188, 189	46032	17, 19	46202	16
41402	182	42794	189	46033	18	46203	17
41403	182	43825	169	46034	16	46204	19
41404	182	43831	161	46035	16	46205	19
41405	182	43854	175	46036	18	46206	19
41406	182	43856	175	46037	18	46208	19

Order No.	Page						
46209	19	46495	108	46587	117	31001871	78, 89
46216	30	46496	106	46588	117	31001872	78, 89
46217	30	46497	105	46589	117	31001873	78, 89
46218	30	46498	126	46590	158	31001874	78, 89
46219	30, 31	46499	126	46591	159	31001875	78, 89
46220	23	46500	126	46592	159	31001876	78
46221	23	46501	126	46593	159	31001886	78
46222	23	46502	21	46594	159	31001887	78
46223	23	46507	33	46595	159	31001888	78
46224	23	46508	33	46605	32	31001889	78
46225	23	46509	33	46606	32	31002033	78
46229	106	46510	33	46607	128	31003573	77
46247	107	46511	33	46608	128	31003644	77
46253	105	46512	33	46609	128	31003669	77
46254	31	46517	28	46989	177	31003677	77
46270	54, 64	46518	28	53510	188, 189	31004595	107
46271	54, 64, 68	46519	28	53511	188	31010542	55, 68, 69
46272	54, 64	46520	28	53512	188	31010776	54, 55
46273	54, 64, 68	46521	30	53513	188	31010795	54
46280	64, 65	46522	30	53514	188	31010801	55
46297	106	46523	73	53515	188	31010818	69
46331	106	46524	73	53516	188	31010836	54
46332	106	46528	16	53550	189	31010837	55
46333	107	46529	16	53551	189	31010896	55, 69
46334	107	46530	73	53552	189	31010945	54, 55, 69
46335	107	46531	73	53553	189	31010947	54, 55, 69
46339	108	46532	73	53554	189	31010949	54, 55, 69
46344	30	46533	73	53555	189	31011003	68
46345	30	46534	73	53556	189	31011041	55, 69
46346	30	46535	73	342856	161	31011246	68
46347	30	46536	73	343904	177	31011247	68
46348	107	46537	73	345514	33	31011254	55
46349	107	46538	73	345515	33	31011255	69
46364	107	46539	73	366035	68	31011274	127
46365	107	46540	73	366043	68	31011275	127
46366	30	46541	73	366045	68	31011276	129
46367	30	46542	73	367453	118	31011277	129
46368	30	46543	73	367567	68	31011278	68
46369	30	46544	73	367568	68	31011281	54
46381	108	46545	73	372012	118	31011288	68
46391	107	46546	73	372014	118	31011337	54, 55
46418	105	46547	73	383166	116, 118, 119	31011349	54
46439	106	46548	73	383167	116, 118, 119	31011649	54, 55, 69
46440	113	46549	73	383168	116, 118, 119	31011657	55
46459	78	46551	23	383169	116, 118, 119	31011658	55
46460	78	46552	23	31000752	78	31011660	55
46466	19	46553	23	31001179	116	31011673	55, 69
46468	19	46554	23	31001261	78, 89	31011674	55, 69
46485	29	46560	64	31001278	78	31011675	55, 69
46487	106	46561	64	31001410	78	31011676	55, 69
46488	105	46562	64, 65	31001572	78	31011677	55, 69
46489	78, 108	46563	64	31001575	78	31011678	55, 69
46490	105	46582	23	31001842	78	31011679	55, 69
46491	108	46583	117	31001847	78	31011680	55, 69
46492	108	46584	117	31001868	78	31011681	55, 69
46493	108	46585	117	31001869	78	31011682	55, 69
46494	105	46586	117	31001870	78	31011683	55, 69

Order No.	Page		
31011687	55, 69	KDH	165
31011688	55, 69	KDS	165
31011689	55	NA71	163
31011690	55	NA72	163
31011691	55	NA73	163
31011692	54, 55	NA74	163
31011693	55, 69	NW10	165
31011695	55, 69	NW71	164
31011697	54, 68	NW72	164
31011698	54, 68	NW73	164
31011699	54, 68	NW74	164
31011700	54, 68	Order No.	Page
31011701	68	Order No.	Page
31011702	69	S40	163
31011704	69	S40L	163
31011705	69	S70	163
31011706	69	S70L	163
31011707	69	TVD	165
31011709	54	TW1	164
31011716	54, 55	TW2	164
31011741	69	WTW2	164
31011742	69		
31011743	69		
31011744	69		
31011745	69		
31011746	69		
31011747	69		
31011757	69		
31011758	69		
31011759	69		
31011760	69		
31011761	69		
31011762	69		
31011766	55, 69		
31011778	55, 69		
31011779	55		
31011863	54		
355908/355909	31		
40645*	139		
41421/8102	184		
41422/8102	184		
41423/8102	184		
41424/8102	184		
41425/8102	184		
41426/8102	184		
41427/8102	184		
41430/8102	185		
41432/8102	185		
41433/8102	185		
41434/8102	185		
41435/8102	185		
41436/8102	185		
41437/8102	185		
41438/8102	185		
46234/46237	31		
46235/46236	31		
KBW	165		

General Terms and Conditions of ZARGES GmbH

1. Scope

- 1.1 Our sales terms only apply to companies within the context of paragraph 1 of §310 of the BGB.
- 1.2 Our sales terms apply exclusively. Conflicting conditions or customer conditions that deviate from our sales terms shall not be recognised if we do not consent to them explicitly in writing. Our sales terms shall also apply without reservation in cases where we complete the delivery to the customer, despite being aware that the customer has contradictory or deviating conditions.

2. Formation of the contract

- 2.1 Our product offering on the Internet, in brochures and other printed media shall remain subject to change. We reserve the rights to all illustrations, drawings, calculations and other documents, including designs provided within the context of an offer. This shall also apply to written documents that are indicated as being confidential. Upon request or in the event that the contract is not awarded to the customer, these documents must be returned immediately. The customer may only pass these on to third parties with our explicit written permission.
- 2.2 Orders are offers from our customers. They may be accepted by us in writing with an order confirmation within two weeks of receipt.
- 2.3 No oral side agreements shall be made.

3. Content of contracts that govern the production of parts according to plans or drawings from the customer

Special tools for completing the contracts shall be invoiced to our customers at cost price. These tools shall remain our property. Upon completion of the contract, the tools will be stored by us for one year. On expiry of this period, the tools will be destroyed.

4. Prices

Our prices are net prices in EURO. Prices do not include packaging. Packaging will be invoiced separately. VAT shall be indicated on the invoice separately according to the legal amount on the day the invoice is submitted.

5. Delayed payment

Unless otherwise stipulated in the order confirmation, the purchase price will fall due without deductions within 30 days from date of invoice.

If the delivery is deficient, any counterclaims of the customer arising from this contract, in particular rights of retention, remain unaffected.

6. Delivery time

6.1 The beginning of an agreed or indicated delivery time requires clarification of all technical questions in advance.

6.2 Adherence to our obligation to deliver also requires timely and correct fulfilment of the customer's own obligations. The right of exemption on the grounds of failure to fulfil contractual conditions remains reserved.

6.3 If the customer delays acceptance of the delivery or if other co-operative obligations are violated, then we shall be entitled to demand remuneration for additional costs and possible damage incurred. We reserve the right to subsequent claims.

6.4 In cases of 6.3, the risk of accidental destruction or of accidental damage caused to the purchased goods shall be transferred to the customer when acceptance of the delivery or payment (arrears) is delayed.

6.5 We shall be liable in accordance with the legal provisions in as far as the sales contract in question represents a forward transaction within the scope of point 4 of paragraph 2 of §286 of the BGB or §376 of the HGB. We shall also be liable in accordance with the legal provisions in cases where the customer is entitled to claim that the interest in fulfilment is void as a result of a delivery delay caused by us.

6.6 Furthermore, we shall also be liable in accordance with the legal provisions in the event that a delayed delivery results from a wilful or grossly negligent breach of contract on our part. Responsibility on behalf of our representatives or vicarious agents is to be attributed to us.

6.7 We shall also be liable according to legal provisions if the delivery delay for which we are responsible involves a culpable violation of an important contractual obligation. In the event of a simple negligent violation of a contractual obligation whose fulfilment is required to enable the proper execution of the contract and whose adherence the customer generally relies on and may rely on (material contractual obligation), our liability is limited to the foreseeable damage that may typically occur.

6.8 Otherwise, in cases of delayed delivery, we shall be liable to pay compensation for each complete week of delay within the scope of a flat-rate delay penalty amounting to 0.5 % of the delivery value per week, but with maximum liability of 2 % of the delivery value.

6.9 Other statutory claims of the customer remain unaffected.

7. Transfer of risk

Unless otherwise stipulated in the order confirmation, the transfer of risk with regard to the delivery shall be agreed to as "ex works".

8. Liability for defects

8.1 The customer's rights regarding defects are subject to the customer successfully fulfilling his obligation to examine the goods and report defects in accordance with §377 of the HGB.

8.2 Provided a defect is present in the purchased item, the customer

is entitled to claim supplementary performance. Provided a claim to supplementary performance is submitted, we may choose to correct the defects or deliver a new, defect-free item. In the case of supplementary performance, we shall be obligated to cover all costs involved in correcting the defects, provided that these do not increase as the result of the purchased item being at a location other than the place of fulfilment.

8.3 If supplementary performance is unsuccessful, the customer may choose to withdraw or demand a price reduction.

8.4 In wilful and gross negligence on the part of us or our legal representatives or vicarious agents, we shall be liable in accordance with legal provisions.

8.5 We shall be liable in accordance with the legal provisions in cases where we culpably violate an important contractual obligation. In the event of a simple negligent violation of a contractual obligation whose fulfilment is required to enable the proper execution of the contract and whose adherence the customer generally relies on and may rely on (material contractual obligation), our liability is limited to the foreseeable damage that may typically occur.

8.6 The statutory liability on account of culpable negligence to life, limb or health shall not be affected; this applies also if we have maliciously concealed the defect or if we have assumed a warranty for the properties of the item, or for liability strictly prescribed according to the Product Liability Act.

8.7 Unless otherwise specified above, our liability shall be excluded.

8.8 The limitation period for claims involving defects shall be set at 12 months beginning with the transfer of risk. This shall not apply to cases involving the sale of an item that would normally be used for a given structure and that in turn resulted in the damage in question.

8.9 The limitation period in the case of a delivery recourse according to §§ 478 and 479 of the BGB shall remain unaffected. This period is 5 years, beginning with delivery of the defective item.

9. Joint liability

9.1 Any and all liability for damages in addition to the liability envisaged in 8 above is excluded regardless of the legal nature of the claim being asserted. This shall apply especially to damage compensation claims resulting from default upon formation of the contract, due to other violations of obligation, or due to criminal claims to compensation for damage to property according to §823 of the BGB.

9.2 The limitation in 9.1 also applies in cases where the customer demands reimbursement for wasted expenditures instead of claiming compensation for damage in place of performance.

9.3 Insofar as our liability for compensation of damages is excluded or limited, this shall also apply with regard to liability for personal damage compensation vis-à-vis our employees, workers, colleagues, representatives and vicarious agents.

10. Retention of title of ownership

10.1 We shall retain the title of ownership to goods delivered by us until all payment obligations resulting from the delivery contract have been fulfilled.

10.2 In the event of conduct by the customer which is in breach of the contract, in particular non-payment of the due purchase price, we are entitled to cancel the contract according to the statutory regulations and to request that the goods are handed on the grounds of the retention of title of ownership. If the customer fails to pay the purchase price as owed, we may only assert these rights if we have set the customer an appropriate payment deadline which has not been met, or if such a deadline as provided by law has become legally superfluous.

10.3 The customer is under obligation to handle the purchased item with due care. In particular, the customer is under obligation to insure the purchased item against damage from fire and water as well as theft up to the amount of its initial value. If maintenance and inspection work is required, the customer shall complete this in a timely fashion at own cost.

10.4 In the case of seizure or other intervention on behalf of third parties, the customer must inform us immediately in writing so that we may dispute this according to §771 of the ZPO. If the third party is not in a position to provide remuneration for the legal and extra-legal costs connected with this dispute according to §771 of the ZPO, the customer shall be held liable for the resulting loss incurred by us.

10.5 The customer is under obligation to store and label the purchased item separately for as long as the retention of title remains. However, the customer shall be entitled to sell the purchased item via regular business proceedings. In spite of this, the customer shall herewith relinquish all claims against the purchaser or third parties resulting from a resale in the amount of the final invoiced sum, including sales tax on our payments receivable, and in particular, regardless of whether the purchased item has been resold without or after processing. The customer shall remain entitled to collect our claims, even after relinquishment. The ordering party must account for incoming amounts that are offset against relinquished claims separately. Our authority to collect claims ourselves shall remain unaffected by this. However, we undertake not to collect these claims, provided the customer fulfils the obligation to pay us with the revenues collected and is not in arrears, and especially if no application for the opening of composition or insolvency proceedings has been filed and payment has not been suspended. If this is the case, however, the customer must at our request inform us of relinquished claims

and debtors, provide us with all information required for collection, all associated documents and inform debtors regarding the relinquishment of the claims to us.

10.6 The customer shall also be entitled to process or convert the purchased item within the scope of regular business proceedings. However, this will always be carried out on our behalf. Where the purchased item is processed using objects that do not originate from us, we shall acquire joint ownership of the new item in the ratio of the value of the purchased item – our final invoiced sum plus sales tax shall be authoritative in this case – against that of the processed objects at the time of processing. Furthermore, the item resulting from the processing shall be subject to the same retention of title as the delivered purchased item.

10.7 Where the purchased item is inseparably integrated with objects that do not belong to us, we shall acquire joint ownership of the new item in the ratio of the value of the purchased item – our final invoiced sum plus sales tax shall be authoritative in this case – against that of the integrated objects at the time of integration. Where integration takes place in such a manner that the customer's item may be considered to be the main item, it is agreed that the customer will transfer proportionate joint ownership to us. The customer shall hold the sole title or joint title thus arising on our behalf.

10.8 The customer shall also relinquish to us claims against third parties that result from integration of the purchase item with real estate as a security on our own claims against the customer.

10.9 We are under obligation, on request by the customer, to release our securities insofar as the value of our securities exceeds the secured claim by more than 10%. The selection of securities to be released shall be determined by us.

11. Claims

We are entitled to assign our claims against the customer to third parties.

12. Court of jurisdiction

The court of jurisdiction shall be the company's location in 82362 Weilheim, Germany. Nevertheless, we reserve the right to bring suit against the customer at the customer's court of jurisdiction.

13. Place of fulfilment

Unless otherwise stipulated by the order confirmation, the place of fulfilment is the company's location in 82362 Weilheim, Germany.

14. Applicable law

The law of the Federal Republic of Germany shall apply with the exception of the UN international trade law.

Mailbox address:

PO box 16 30, D-82360 Weilheim

Company address:

Zargesstraße 7, D-82362 Weilheim

Court of register:

Munich HRB 169642, ILN 40 03866 00000 5

Directors:

Maximilian Treptow

General Terms and Conditions

Minimum order value: For orders amounting to less than € 250, there is a surcharge of € 15 per order.

Damage caused in transit: For insurance reasons, we can only accept such claims if notification of claim is submitted punctually. In case of damage, please contact your sales representative.

Return consignments: Goods can only be returned to us on prior agreement (ZARGES returns delivery note). Consignments must be returned carriage paid. We charge a processing fee of 10 % plus VAT, but at least € 50 plus VAT, for returns. Any reconditioning costs will also be deducted from the amount credited. Goods must be returned in the original, sealed ZARGES packaging. Assembled goods and goods produced to customer specifications may not be returned.

Warranty: Our warranty lies within the statutory requirements.

You can also find our terms and conditions under:
www.zarges.com/uk/terms-and-conditions/





ZARGES –
Access.
Packaging,
transportation.
Special solutions.

For more than 85 years, the brand name ZARGES has been synonymous with premium quality and continuous innovation. As an innovation leader, we are constantly improving our range and creating solutions and products that are consistently tailored to your needs. Our good ideas always come from closely working together with you, the customer.

Our aim is to always provide you, the professional, with the right solution for any requirement. For your safety and efficiency.

Further information is available online:
www.zarges-medical.com

ZARGES GmbH
Zargesstr. 7
D-82362 Weilheim
Tel.: +49 881 687-132
Fax: +49 881 687-525
medical@zarges.de